



Training Course on Geothermal Electricity

**8 - 11 October 2013,
Pisa, Italy**

Manual

This document has been edited by:

Adele Manzella and Isabella Nardini,
National Research Council CNR Institute of Geosciences and Earth Resources,
Via Moruzzi 1, 56124 Pisa, Italy

Dimitrios Mendrinou and Costas Karytsas,
Centre for Renewable Energy Sources and Saving,
19th km Marathonos ave., 19009 Pikermi Attikis, Greece

for the *Third Training Course on Geothermal Electricity*, 8–11 October 2013, in Pisa, Italy,
organized in the framework of the GEOELEC project.

The GEOELEC project is a pan-European project on geothermal electricity, supported by the *Intelligent Energy Europe programme* of the EU. The objective of the GEOELEC project is to convince decision-makers about the potential of geothermal electricity in Europe, to stimulate banks and investors in financing geothermal power installations and finally, to attract key potential investors such as oil and gas companies, and electrical utilities to invest in geothermal power. One key element will be to present them the huge geothermal potential in Europe (<http://www.geoelec.eu/>).

GEOELEC Partners

European Geothermal Energy Council (EGEC)
Bureau De Recherches Géologiques et Minières (BRGM), France
Centre for Renewable Energy Sources and Saving (CRESES), Greece
Consiglio Nazionale delle Ricerche, Istituto Di Geoscienze e Georisorse (CNR-IGG), Italy
Asociacion De Productores De Energias Renovables (APPA), Spain
Gaßner, Groth, Siederer & Coll. (GGSC), Germany
Energie Baden-Württemberg AG (EnBW), Germany
Mannvit, Iceland
Helmholtz Centre Potsdam German Research Centre for Geosciences (GFZ), Germany
Nederlandse Organisatie Voor Toegepast Natuurwetenschappelijk Onderzoek (TNO),
Netherlands

In references, each contribution of this document will be referenced as the following example:

van Wees, J.-D., Durst, P., Manzella, A., and Nardini, I., 2013. Geothermal exploration. Manzella, A., Nardini, I., Mendrinis, D., and Karytsas, C. (eds.), in Manual of the Training Course on Geothermal Electricity, 8–11 October 2013, Pisa, Italy, pp. 9–14.

Keywords: Geothermal electricity, market aspects, legal/environmental and financial aspects, Enhanced Geothermal Systems (EGS), geothermal exploitation/exploration, resource assessment, EGS technology, geothermal well drilling, reservoir exploitation assessment, flash steam and binary technology, plant operation, energy supply and grid integration

Contents

Day 1 - 8 October 2013.....	6
Session I - Geothermal exploration.....	8
P. Durst, A. Manzella, I. Nardini and J.-D. van Wees.....	8
Resource assessment: targets and tools.....	8
Geothermal assessment and exploration: an overview	9
Session II - EGS technology.....	13
C. Dezayes, P. Durst, and J.-D. van Wees and G. Zimmermann.....	13
Introduction.....	14
Theoretical background	14
EGS case studies	14
Outlook.....	16
The Soultz projects: towards the deep geothermal exploitation	18
Day 2 - 9 October 2013.....	19
Session III - Plant operation, energy supply and grid integration	21
F. Heilemann and S. Reith	21
Regulation and energy trade.....	21
Electricity Grid	22
Demand for geothermal power	24
Grid integration of an increasing share of renewable power generation – challenges for the network and system operation.....	24
Costs of grid integration.....	25
Process of grid integration	27
Session IV - Flash steam and binary technology.....	29
P. Bombarda and F. Sabatelli.....	29
Process flow and steam gathering system.....	30
Mechanical equipment and operation and maintenance	37
Day 3 - 10 October 2013.....	42
Session V - Market aspects.....	46
C. Karytsas and D. Mendrinou	46
International Geothermal Market overview.....	46
Session VI - Legal, environmental and financial aspects	54
L. Angelino, R. Barontini, F. Batini, M. Borzoni, P. Dumas, M. Frey, F. Jaudin, R. Kutschick, I. Nardini, T. Reif, F. Rizzi, B. Sanner, L. Tryggvadóttir and G. Wolter.....	54
Sustainable development of a geothermal project	54
Risk insurance for geothermal projects	54
Regulatory barriers.....	56
Financing costs of geothermal power projects.....	59
Investment analysis.....	61
Environmental issues	62
Session VII - Drilling	65
R. Bertani, A. Lazzarotto and L. Serniotti.....	65
Abstract	65
PARTNERS	1

Day 1 - 8 October 2013

Presenters

J.-D. van Wees, P. Durst A. Manzella and I. Nardini

Curricula vitae



Jan-Diederik van Wees

Professor, principal scientist
Nederlandse Organisatie Voor Toegepast
Natuurwetenschappelijk Onderzoek, TNO,
Netherlands
Sustainable geo-Energy
Jan_diederik.vanwees@tno.nl

Prof. Dr. Jan-Diederik van Wees is principal scientist of geothermal research at TNO, and is extra-ordinary professor at Utrecht University on tectonics and geothermal energy. He has published over 60 papers in leading international journals on tectonics, resource assessment, reservoir engineering, and techno-economic models. His current research expertise focuses towards enhanced geothermal systems (EGS) and direct use applications in Europe. Van Wees serves in various co-ordinating roles in major European and national geothermal research projects, including sub-program management (resource assessment) in the Joint Program on Geothermal Energy of the European Energy Research Alliance. Under his leadership, TNO has developed various state-of-the-art geothermal information systems and performance assessment methodologies, including thermoGIS for geothermal aquifers in the Netherlands and a decision support system for the performance assessment of enhanced geothermal systems. Further TNO is active in the EU project GEISER focused towards in depth understanding and mitigation of induced seismicity at geothermal operations.



Pierre Durst

Hydrogeologist PhD
Bureau De Recherches Géologiques et
Minières, BRGM, France
p.durst@brgm.fr

Pierre Durst is a Research Scientist, who did his PhD on geochemical modelling on the Soultz-sous-Forêts geothermal project. He worked five years on geochemical and reservoir modelling related to CO₂ storage, then four years on hydrogeological modelling related to water resources management and geothermal resources assessment. Currently he is working on geothermal resources assessment as well as on potential risks and impacts related to geothermal exploitation.



Adele Manzella
Geophysicist M.Sc.
National Research Council of Italy, CNR
manzella@igg.cnr.it

Adele Manzella, Senior Research Scientist, worked in seismology, numerical modeling for seismic and electromagnetism. Working since 1990 as a geophysicist in geothermal exploration to conduct field and theoretical investigations of geothermal systems in Italy and abroad, in particular using the magnetotelluric method. On 2006 obtained the G.W. Hohmann Award for Teaching and Research in Applied Electrical Geophysics, SEG Foundation, for “outstanding application of electrical and electromagnetic methods to the study of geothermal resources”. Responsible for over 20 projects related to geothermal, crustal and volcanology exploration using geophysical methods, lectured at the annual International School of Geothermics of Pisa and at short courses on geothermal exploration in Chile, North Korea, Ecuador, Ethiopia, Uruguay and Italy, authored about 40 articles in peer-reviewed journals with geothermal-related subjects, and over 100 presentations at international symposia and congresses. She is the scientific coordinator of the two main CNR projects (VIGOR and ATLAS) of geothermal assessment of southern Italy.



Isabella Nardini
Ph.D. in Geochemistry and Petrology
National Research Council of Italy, CNR
nardini@igg.cnr.it

Isabella Nardini is a geologist as basic formation, specialized in geochemistry petrology of volcanic and magmatic rocks; the personal expertise was progressively enlarged to geothermal. BS and MS degrees in Earth Sciences at the University of Pisa in 1999. Ph.D. in Geochemistry and Petrology in 2004 at University of Pisa (I). In 2007 started to work on high enthalpy fluids and fluid-rock interaction processes applied geothermal resources. Expertise in geochemical microanalyses: XRF, ICP-MS. In situ micro-analytical methods: EMPA-WDS, SEM-EDS, LAM-ICP-MS, thermometry, mass spectrometry (H, O, He Pb, Sr, Nd isotopes) and and micro-drilling technique applied to natural and synthetic samples, dating. Management of the EERA-Joint Programme on Geothermal Energy since 2010. Author and co-author of 35 publications on national and international scientific journals and proceedings of conferences/workshop.

Session I - Geothermal exploration

P. Durst, A. Manzella, I. Nardini and J.-D. van Wees

Abstract

This chapter is dedicated to give an overview of geothermal energy from a geological point of view. We will develop the mechanisms and processes involved in order to provide basic comprehension of how the potential exploitation relates to Earth structure and dynamic, as following:

- Thermal process and Earth internal structures: Where does that heat come from? How is it distributed and transported within the Earth?*
- Heat flow and geothermal gradient: This chapter will focus on the repartition of temperature in the first kilometres of the Earth crust, where the heat can potentially be exploited.*
- Plate tectonic and geothermal resources: Where are located the potential exploitation area in regards to Earth dynamic?*
- Different types of geothermal energy: A brief description of the potential use of geothermal energy, depending of the available resources and the expected use.*

References

- Calcagno P., Bouchot V., Thinon I., Bourguin B., 2012. A New 3D Fault Model of the Bouillante Geothermal Province Combining Onshore and Offshore Structural Knowledge (French West Indies), Tectonophysics 526-529 (2012) 185-195.*
- Genter A., Guillou-Frottier L., Feybesse J.-L., Nicol N., Dezayes C., Schwartz S., 2003. Typology of potential Hot Fractured Rock resources in Europe. Geothermics 23, p. 701-710.*

Resource assessment: targets and tools

Geothermal exploration is aimed at detecting the geothermal resource at depth, defining its physical and chemical features. Geothermal resources can be analysed on different scales and for various purposes, following a step-by-step procedure and zooming from regional, local and reservoir scales. Following the general overview of the previous session, Session IV will analyze in detail how to locate a potential geothermal reservoir, defining its geometry, size and the heat content, and then retrieve information regarding productive zones or areas where stress condition are suitable for EGS development by enhancement of natural permeability. Different tools and approaches can be used to investigate geothermal resources, which depend on the geological context of the site, from sedimentary to volcanic to crystalline reservoirs, and on the nature of the resource, both for natural system and EGS perspectives. The course will provide an overview of the most common geological, geophysical, geochemical methodologies and the collected information, and will explain how to integrate the different data and provide the conceptual model of the resource to be used for locating the exploratory drilling.

With the help of case studies, the presenter will exemplify the exploration procedure and will show what are the main parameters of a conceptual geothermal model, how to compile a

body of basic data against which the results of future monitoring can be viewed, and to determine pre-exploitation values of environmentally sensitive parameters.

Keywords: Geothermal assessment, exploration methods, geology, geophysics, geochemistry, monitoring parameters, environment

Geothermal assessment and exploration: an overview

The objectives of geothermal exploration are:

- To identify geothermal phenomena.
- To ascertain that a useful geothermal production field exists.
- To estimate the size of the resource.
- To determine the type of geothermal field.
- To locate productive zones.
- To determine the heat content of the fluids that will be discharged by the wells in the geothermal field.
- To compile a body of basic data against which the results of future monitoring can be viewed.
- To determine the pre-exploitation values of environmentally sensitive parameters.
- To acquire knowledge of any characteristics that might cause problems during field development.

The relative importance of each objective depends on a number of factors, most of which are tied to the resource itself. These include anticipated utilization, technology available, economics, as well as situation, location and time, all of which affect the exploration programme.

Before attempting an exploration program, it is important to define the main features of a geothermal system and therefore the exploration targets.

A conventional geothermal system is made up of four main elements: a heat source, a reservoir, a fluid, which is the carrier that transfers the heat, and a recharge area. The heat source is generally a shallow magmatic body, usually cooling and often still partially molten. The volume of rocks from which heat can be extracted is called the geothermal reservoir, which contains hot fluids, a summary term describing hot water, vapour and gases. A geothermal reservoir is usually surrounded by colder rocks that are hydraulically connected with the reservoir. Hence water may move from colder rocks outside the reservoir (recharge) towards the reservoir, where hot fluids move under the influence of buoyancy forces towards a discharge area.

The mechanism underlying geothermal systems is by and large governed by fluid convection. Convection occurs because of the heating and consequent thermal expansion of fluids in a gravity field; heat, which is supplied at the base of the circulation system, is the energy that drives the system. Heated fluid of lower density tends to rise and to be replaced by colder

fluid of high density, coming from the margins of the system. Convection, by its nature, tends to increase temperatures in the upper part of a system as temperatures in the lower part decrease.

One aspect of a conventional geothermal system is that it must contain great volumes of fluid at high temperatures or a reservoir that can be recharged with fluids that are heated by contact with the rock. A geothermal reservoir should lie at depths that can be reached by drilling. It is unreasonable to expect to find a hidden hydrothermal system at depths of less than 1 km; at the present time it is not economic to search for geothermal reservoirs that lie at depths of more than 5 km, although actual technology allows reaching depth up to 10 km. In order to be productive, a well must penetrate permeable zones, usually fractures, which can support a high rate of flow. When this requirement is not met, actual technological development is attempting to enhance the natural permeability (EGS). Enhancing a geothermal system generally involves drilling along deviated well paths and with large diameters, drilling with formation damage mitigating technologies, stimulating the reservoir by hydraulic fracturing, and/or targeting fault zones that will produce with high flow rates, which are usually higher than those in hydrocarbon production. Thus, one of the key geological issues, especially critical for EGS development, is knowledge of the stress field and an understanding of geomechanics in the subsurface. The geological characterization must therefore also include various methods that constrain the stress field of a reservoir and elucidate the stress states along faults slated for stimulation. Specific stress conditions are then required, and they should be defined during exploration.

The geological setting in which a geothermal reservoir is to be found can vary widely. The largest geothermal fields currently under exploitation occur in rocks that range from limestone to shale, volcanic rock and granite. Volcanic rocks are probably the most common single rock type in which reservoirs occur. Rather than being identified with a specific lithology, geothermal reservoirs are more closely associated with heat flow systems. As far as geology is concerned, therefore, the important factors in identifying a geothermal reservoir are not rock units, but rather the existence of tectonic elements such as fracturing, and the presence of high heat flow.

The high heat flow conditions that give rise to geothermal systems commonly occur in rift zones, subduction zones and mantle plumes, where large quantities of heat are transported from the mantle to the crust of the earth. Geothermal energy can, however, also occur in areas where thick blankets of thermally insulating sediment cover basement rock that has a relatively normal heat flow. Geothermal systems based on the thermal blanket model are generally of lower grade than those of volcanic origin.

The different elements of a geothermal system represent targets for the application of geological, geophysical and geochemical prospecting techniques. Because of the high temperatures involved, both in the geothermal reservoir and in the source of the geothermal system, we can expect major changes to have taken place in the physical, chemical and geological characteristics of the rock, all of which can be used in the exploration project.

Heat is not easily confined in small volumes of rock. Rather, heat diffuses readily, and a large volume of a rock around a geothermal system will have its properties altered. The rock

volume in which anomalies in properties are to be expected will, therefore, generally be large. Exploration techniques need not offer a high level of resolution. Indeed, in geothermal exploration we prefer an approach that is capable of providing a high level of confidence that geothermal fluids will be recovered on drilling.

A geothermal assessment program is generally combined with comprehensive assessment of the geologic setting, especially of the tectonic and structural framework. Thus, fruitful exploration strategies typically involve the following:

- Assessment of the geologic and geodynamic setting
- Geochemistry including fluid and rock isotope chemistry
- Structural analysis of faults, fractures, and folds
- Determination of the regional stress field
- Potential methods, mainly gravity and magnetic surveys
- Electrical and electromagnetic methods
- Seismic methods, both active and passive

A typical procedure in a geothermal project foresees exploration to follow a down-scale workflow, summarized in Figure 1.

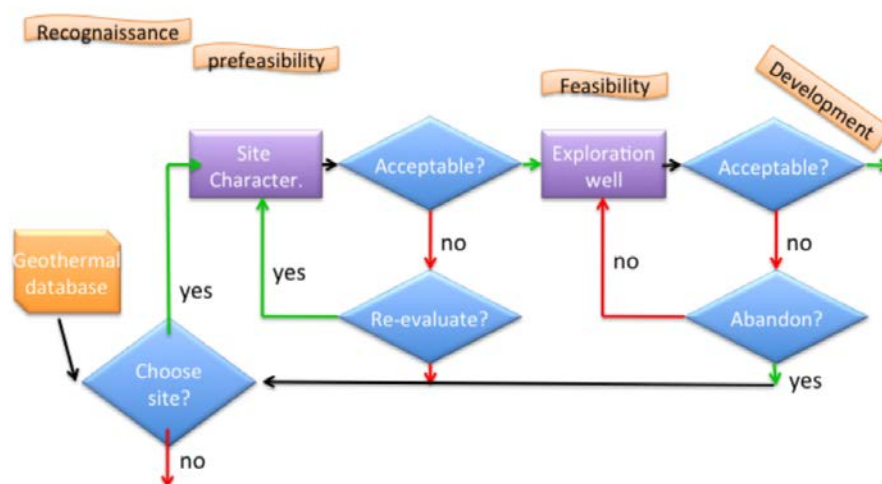

Figure 1. The three phases of a geothermal project development that incorporate exploration.

The assessment programme on a regional basis will begin with a review and coordination of the existing data (reconnaissance phase). All heat flow data acquired previously will have to be re-evaluated, re-gridded, smoothed, averaged and plotted out in a variety of forms in an attempt to identify areas with higher than normal average heat flow. Similarly, the volumes of rocks with ages younger than 106 years should be tabulated in a similar way to provide a longer-range estimate of anomalous heat flow from the crust. Because fracturing is important, levels of seismicity should be analysed, averaged and presented in a uniform format. All information on thermal springs and warm springs should be quantified in some form and plotted in the same format. Comparison of these four sets of data, which relate directly to the characteristics of the basic geothermal model described above, will produce a

pattern that will indicate whether the area possesses the conditions favourable for the occurrence of specific geothermal reservoirs. These areas should then be tested further, by applying some or all of the many geophysical, geological and geochemical techniques designed to locate specific reservoirs from which fluids can be produced. Surface manifestation may also be detected by remote sensing techniques, which may be able to map superficial thermal anomalies and topographic changes associated to shallow geothermal anomalies.

The objective of the more detailed studies is to identify the existence of a productive reservoir at attractive temperatures and depths. Detailed geophysical, geological and geochemical studies will be needed in order to identify drilling locations once a prospect area has been defined from reconnaissance.

Geochemical surveys provide the most reliable indications of reservoir temperatures if the thermal fluids emerge at the surface. In any event, all springs and other sources of groundwater should be sampled and various geothermometer calculations carried out. Some prospect areas will probably show much more positive geochemical indicators than others. This could merely reflect the difference in the amount of leakage from subsurface reservoirs, but it does provide a basis for setting priorities for further testing; the geothermal reservoirs that show the most positive indications from geochemical thermometry should be the ones that are investigated first by other geophysical techniques.

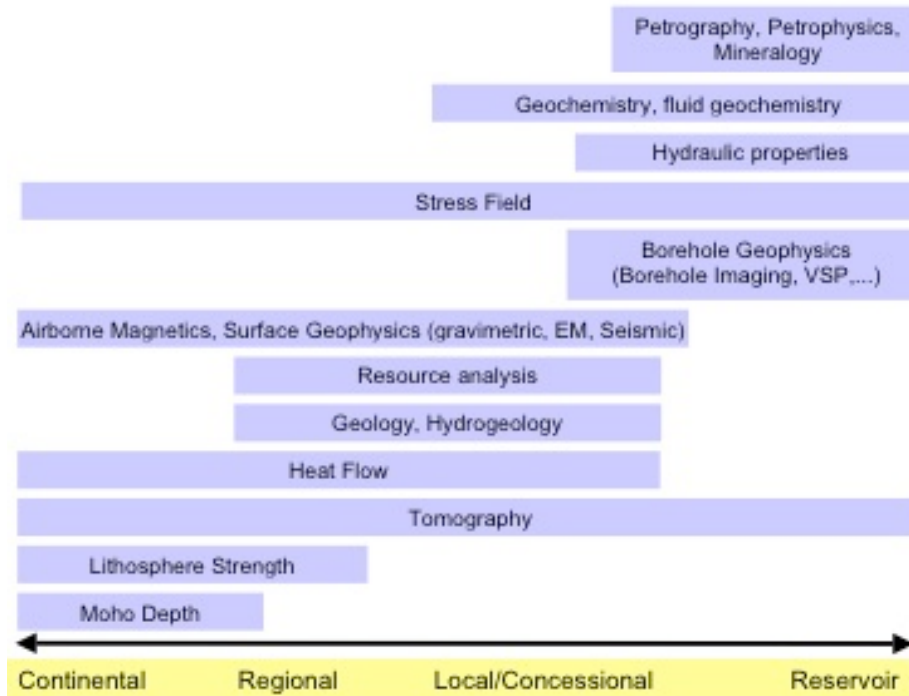

Figure 2. Different information and knowledge available on regional, local/concessional and reservoir scales, to be integrated for site-screening and exploration.

Geophysical methods play a key role in geothermal exploration since many objectives of geothermal exploration can be achieved by these methods. The geophysical surveys are directed at obtaining indirectly, from the surface or from shallow depth, the physical parameters of the geothermal systems. A geothermal system generally causes inhomogeneities in the physical properties of the subsurface, which can be observed to varying degrees as anomalies measurable from the surface. These physical parameters include temperature (thermal survey), electrical conductivity (electrical and electromagnetic methods), elastic properties influencing the propagation velocity of elastic waves (seismic survey), density (gravity survey) and magnetic susceptibility (magnetic survey). Most of these methods can provide valuable information on the shape, size, and depth of the deep geological structures constituting a geothermal reservoir, and sometimes of the heat source. In summary, geothermal exploration for conventional and EGS means, on the one hand, that a reservoir should be understood as a part of a complex geosystem and, on the other hand, it is part of a complex mechanical rock response in the subsurface reacting – either positive or negative – to all manipulations that need to be done from exploration over reservoir access to exploitation. Consequently, geothermal exploration should encompass a broad palette of approaches, which are summarized in Figure 2, from geosystem analysis to reservoir characterization to reservoir geomechanics.

Relevant Publications

- Oskooi, B., Pedersen, L.B., Smirnov, M., Árnason, K., Eysteinnsson, H., Manzella, A., and the DGP Working Group: The deep geothermal structure of the Mid-Atlantic Ridge deduced from MT data in SW Iceland. Phys. Earth Planet. Int., 150, 183-195, 2005.*
- Spichak V., and Manzella A.: Electromagnetic sounding of geothermal zones, Journal of Applied Geophysics, 68, 459–478, 2009. doi: 10.1016/j.jappgeo.2008.05.007.*

Session II - EGS technology

C. Dezayes, P. Durst, and J.-D. van Wees and G. Zimmermann

Abstract

This session provides an insight into subsurface technology of Engineered Geothermal Systems (EGS), in particular the process of hydraulic fracturing and induced seismicity in EGS projects. Basic concepts of geomechanics and hydraulic fracturing, results of hydraulic stimulation and induced seismicity in EGS projects will be covered by lessons learned from the GEISER FP7 project.

The setup of this session is as follows

Part 1 theoretical background:

- *Basics of Rock mechanics, tectonic faulting and seismicity*
- *Hydraulic stimulation : best practice from oil and gas, objectives and physical principles*

Part 2: EGS case studies

- *Enhancing flow rates*
- *Induced seismicity*

Part 3: outlook

- *Mitigation strategies*
- *Best practice guidelines*

Keywords: enhanced geothermal systems, hydraulic stimulation, induced seismicity

Introduction

The development of renewable energies is more urgent than ever. Geothermal energy systems have a strong undeveloped potential in continental Europe that is estimated to be between 10,000 and 50,000 MW. But only in the European magmatic areas in Italy, Iceland and Portugal, production of high temperature heat (>200°C) has been harnessed for the generation of electricity (>1,400 MW). Technological development of site-independent technologies to extract high temperatures at very deep levels and independent from natural hot water resources would allow production of geothermal energy in areas which are not marked by magmatism. There, the key is to use open fractures in high-temperature rock so that water and steam circulating into them can rapidly transfer heat to the Earth's surface. Where fractures are not naturally abundant, one needs to create new fractures or to reactivate existing ones to increase the permeability. This can be carried out by hydraulic stimulation, hydraulic fracturing or acidization, which all consists of injecting fluids at high pressures in the underground. Such so-called enhanced geothermal systems (EGS) hold the key to future growth of geothermal energy but more experience is required to successfully develop these systems.

Theoretical background

Tectonic stress and geomechanical properties of rocks explain jointly the process of natural seismicity as well as the process of breaking rock by fluid injection. Natural fault motions are characterized by shear failure resulting in earthquakes. The spatial distribution and nature of earthquakes is strongly controlled by tectonics, the natural deformation of the earth. Hydraulic fracturing relies on the stress state of the rock and its geomechanical properties. Since decades tensile fracturing, marked by hardly any shear failure, is used routinely in oil and gas to improve the performance of wells. For shale gas and EGS operations hydraulic stimulation often involves the generating of shear fractures in order to connect wells with permeable fractures over large distances.

EGS case studies

Most EGS projects require drilling to several kilometers depth to reach adequate temperatures (about 120°C). In Europe, a few EGS pilots have been performed (Figure 1).

These stimulations are often accompanied by vast amounts of induced seismicity, which can be used to characterize the reservoir, but which is also of major concern when it releases sufficient energy to cause possible surface damage or to be felt by the population.

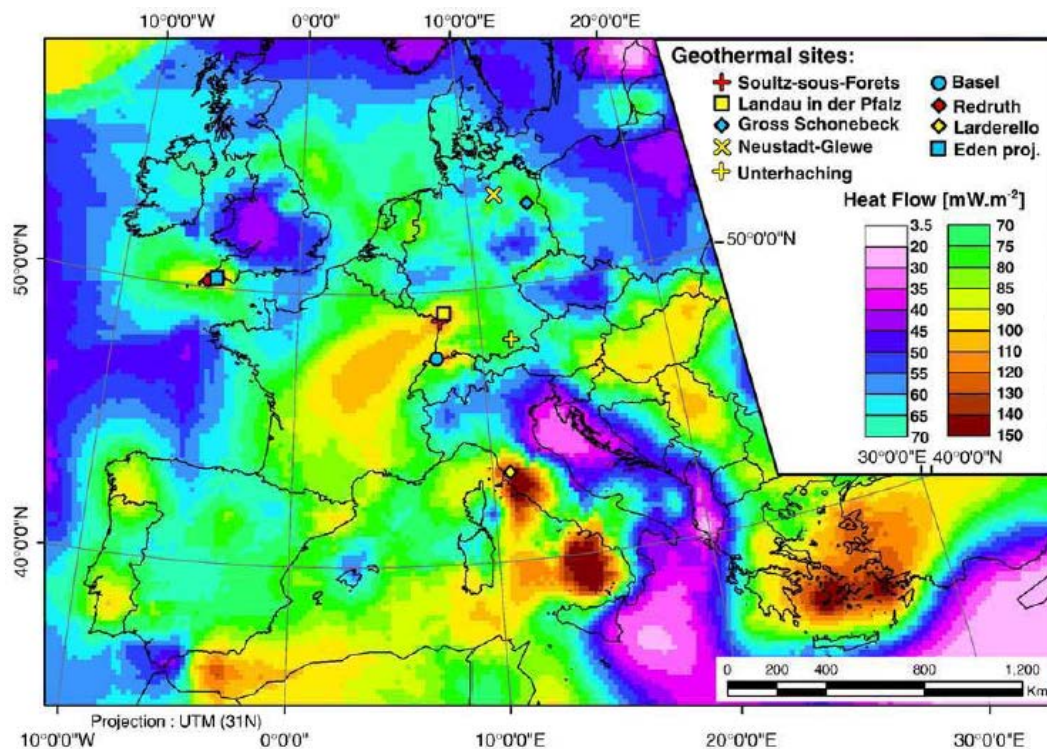

Figure 1. Heat flow map of Europe and geothermal projects.

In this session we present in detail the results from Soutz-sous-Forêts and Groß Schönebeck. Soutz-sous-Forêts was initiated in 1986, and the project has now a long history which is broadly documented) and benefits from a vast amount of field observations in numerous domains (geology, geochemistry, geophysics, petrophysics, hydrogeology, etc.) gathered during the exploration, drilling, stimulation, circulation, production phases. Today, 1.5 MWe net power can be delivered to the French electrical network.

Over the development of the EGS, four wells have been drilled and stimulated to create the heat exchanger prior to production. The bottoms of the holes are aligned in a N170°E direction consistent with the horizontal principal stress direction.

At the current stage, Soutz is producing from a reservoir at around 5000m depth, at T=190°C, with stimulations after the year 2000 in the wells GPK2, GPK3 and GPK4, circulation tests since 2005 and the longest circulation test in 2010. From logging measurements, it has been noticed that the reservoir consists of strongly altered granite with hydrothermally altered and fractured zones. The hydraulic exchanger of the current Soutz reservoir is dominated by such an altered fracture zone, which extends on large scale as a planer structure linking GPK2 and GPK3 in the deeper reservoir.

Groß Schönebeck is developed from a reopened oil and gas well which was deepened to 4294 m depth to serve as an in-situ geothermal laboratory. Nine months after reopening, the bottom hole temperature was 149 °C at 4285 m depth. The reservoir of interest is

composed of sandstones, conglomerates and underlying andesitic volcanic rocks. The sandstones constitute the principal targeted reservoir. They are well-sorted, middle to fine grained, with 8 to 10 % porosity and in-situ permeability of 10 – 100 mD. In contrast to the Dethlingen sandstone formation, the permeability of the volcanic rock is rather high due to connected fractures. Several stimulation operations were carried out in this well at the reservoir level to enhance water productivity and they are discussed in the next section in parallel with the induced seismicity. To complete the doublet system of this EGS site, the production well was drilled in 2007 down to the volcanic rocks. The stress magnitudes in the Dethlingen sandstone at 4.1 km depth were determined to be $S_V=78 - 100$ MPa from density logs, $S_H=98$ MPa (at N18E) estimated from transitional form of stress regime from normal faulting to strike slip faulting, and $S_h=55$ MPa from leak-off tests in both wells. In the volcanic section, mainly the minimal principal horizontal stress is different and is equal to $S_h=72$ MPa. During stimulation, the strongest micro-earthquakes (with $M_w \leq -1$) occurred on a pre-existing fault, which theoretically was relatively critically stressed. The strike and dip of this fracture plane are $17^\circ \pm 10^\circ$ and $52^\circ \pm 10^\circ$ SE respectively.

In Soultz, Groß Schönebeck, and other pilot sites, the observed induced seismicity, spatially lines up in relatively large and planar fault and fracture zones. Mechanical models for seismic rupture clearly demonstrate that the geometrical and rheological alignment of these fractures, in interaction with the pre-existing and perturbed stress field due to hydraulic stimulation is key to induced seismicity. Connecting to critically stressed crustal scale faults, can -in theory- trigger relatively large events.

Outlook

The predicted contribution of EGS in the worldwide geothermal energy production portfolio is significant for 2050. Widespread growth of EGS is anticipated after 2020 since, at that point, easy accessible hydrothermal systems are becoming scarce. Moreover, research and development will enable EGS to be ready for large scale deployment, both in terms of securing public acceptance and environmental safety with regards to induced seismicity and in terms of reducing levelized (the levelized cost of a given energy is the ratio between the sum of all costs necessary to produce this energy over time and the production duration) costs of energy (IEA, 2011).

In Australia and in the USA, generous funding of EGS projects provides the opportunity for these countries to develop EGS technology. In Europe, to face these challenges, the European Energy Research Alliance (EERA) Joint Program on Geothermal Energy (JPGE) aims at providing an outstanding contribution bringing together 20 leading European geothermal research institutions in a single strategically oriented joint research and development program. The EU funds research activities partly under the umbrella of the JPGE which includes for instance the EU project GEISER (2010-2013) that investigates geothermal engineering integrating mitigation of induced seismicity in geothermal reservoirs.

With an emphasis on expanding the geothermal resource base by including potential sites for enhanced geothermal systems (EGS), engineering concepts need to be developed for a

variety of geological settings that are not normally accessed for geothermal electricity production. As the enhancement of a geothermal reservoir involves fracturing of the reservoir rocks, the risks of this process needs to be understood in detail to both increase the probability of creating the enhanced flow paths for fluid circulation to make exploitation of the reservoir economically viable and to reduce the risk of triggering earthquakes that can be felt at the surface, disturb the public and cause damages to buildings.

It is clear that we need a more sound theoretical understanding complemented by hands on experience in pilot projects. For these pilot projects we need guidelines for safe and reliable EGS operations. The EU project GEISER will provide these. Key is a dynamic –forewarning-traffic light system. The reliability of the dynamic model comes from physics and probabilistic based underpinning for seismicity forecasting, calibrated to geological subsurface information and real-time monitoring data. This approach allows adjusting operational conditions to mitigate unsolicited effects and to improve system performance.

Further the guidelines will propose a strategy to enhance public support to EGS projects, based on lessons learned from past projects. A cost-benefit balance for the stakeholders throughout the entire exploration and production workflow is important, capable of identifying and proper addressing different interests and (perceived) risks regarding a specific EGS project. In view of the latter, nuisance and trivial damage should be addressed with care and considered as a significant project risk. For structural damage a procedure is needed to evaluate and compensate the costs involved.

Relevant Publications

- Cloetingh, S., Van Wees, J.D., Ziegler, P., Lenkey, L., Beekman, F., Tesauro, M., Forster, A., Norden, B., Kaban, M., Hardebol, N., Bonte, D., Genter, A., Guillou-Frottier, L., Voorde, M.T., Sokoutis, D., Willingshofer, E., Cornu, T., Worum, G., 2010. Lithosphere tectonics and thermo-mechanical properties: an integrated modelling approach for Enhanced Geothermal Systems exploration in Europe. Earth-Science Reviews 102, 159-206.*
- Bruhn, D., Huenges, E, Agustsson, K, Zang, A, , Rachez, X., Wiemer, S., Van Wees, J.D., Calcagno, P., , 2011. Geothermal Engineering Integrating Mitigation of Induced Seismicity in Reservoirs - The European GEISER Project. GRC transactions, 39.*
- Wassing, B., Van Wees, J.D., Fokker, P., 2012. , Coupled Continuum Modeling of Fracture Reactivation and Induced Seismicity During Enhanced Geothermal Operations. ARMA paper 12-400.*
- Zimmermann, G. Blöcher, G. Reinicke, A Brandt, W. (2011): Rock specific hydraulic fracturing and matrix acidizing to enhance a geothermal system - Concepts and field results. Tectonophysics, 503, 1-2, 146-154.*
- Zimmermann, G; Moeck, I. Blöcher, G. (2010): Cyclic waterfrac stimulation to develop an enhanced geothermal system (EGS): Conceptual design and experimental results.. Geothermics, 39, 1, 59-69.*
- Zimmermann, G. Reinicke, A. (2010): Hydraulic stimulation of a deep sandstone reservoir to develop an Enhanced Geothermal System: Laboratory and field experiments. Geothermics, 39, 1, 70-77.*

The Soultz projects: towards the deep geothermal exploitation

Following the general EGS technology course, this chapter is dedicated to the Soultz-sous-Forêts project as the example of the deep geothermal exploitation. We will develop the 20 years scientific research to end at the application of non-conventional geothermal exploitation, as following:

- *Concept and history: why develop the deep geothermal energy, how, the main research projects and their contributions.*
- *General presentation of the Soultz project: partners, main steps of the project.*
- *General context: why this location, main characterisation as geology, stress field, fluids,...*
- *Principle of permeability enhancing: how create thermal exchanging surfaces, which mechanisms, result and consequences.*
- *Feasibility of a deep geothermal loop: development of the upper reservoir (3500m) and the first circulation test.*
- *Toward the 200°C, development of the lower reservoir at 5km depth: deep wells, production tests, tracer tests, hydraulic stimulation, induced microseismicity, chemical stimulation, understanding of the hydraulic circulation.*
- *Exploitation of the 200°C: circulation test and tracer test, circulation model, pumps, surface power plant and electrical production.*
- *Issues, potentiality and industrial development.*

References

- Dezayes C., Genter A., Valley B., 2010. *Overview of the Fracture Network at Different Scales Within the Granite Reservoir of the EGS Soultz Site (Alsace, France), Proceedings World Geothermal Congress 2010, Bali, Indonesia.*
- Genter A., Evans K., Cuenot N., Baticci F., Dorbath L., Graff J.-J. Sanjuan B., 2009. *The EGS Soultz Project (France): From Reservoir Development to Electricity Production, GRC Transactions, Geothermal Resources Council (GRC) Annual Meeting 2009, Reno, USA.*

Day 2 - 9 October 2013

Presenters

F. Heilemann, S. Reith, F. Sabatelli and P. Bombarda.

Curricula vitae

	<p>Franz Heilemann Dr.-Ing., Senior Manager EnBW Energie Baden-Württemberg Regional AG, Germany f.heilemann@enbw.com</p>
---	---

Dr.-Ing. Franz Heilemann is experienced in planning, construction and operation of electricity grids on all voltage levels. The development of interdisciplinary smart grid strategies with integration of renewables and customers as well as economic analyses, efficiency benchmarks and regulatory management are part of his work at the network operator EnBW Regional AG. His dissertation at the University of Stuttgart was focused on stability problems of large interconnected power systems and their improvement.

	<p>Sören Reith University of Stuttgart, Germany Soeren.Reith@ier.uni-stuttgart.de</p>
---	--

Sören Reith did his Bachelor at the Baden-Wuerttemberg Cooperative State University Karlsruhe (DHBW), followed by his Master at the Karlsruhe Institute of Technology (KIT), which he finished in 2011. Parallel to his studies he was working in different departments of EnBW. Since 2009 he gathered experience in the research and development department of EnBW. Currently he is working on his doctoral thesis in the field of deep geothermal energy production in cooperation with the University of Stuttgart.



Fabio Sabatelli

Chemical Engineer, head of geothermal plant design in the Engineering Division of Enel Green Power, Italy

Fabio Sabatelli is a Chemical Engineer, MSc, from the University of Pisa in 1979.

He has been working within Enel group since 1981, dedicating his career to geothermal energy; since 2002 he is head of geothermal plant design in the Engineering Division of Enel Green Power, the company of Enel group dedicated to the development of renewable energy sources. In his present role, Dr. Sabatelli managed the engineering of geothermal power plants and associated gathering system for the projects built in the last decade by EGP: Nuova Lagoni Rossi (15 MW), Sasso 2 (20 MW), Nuova San Martino (40 MW), Nuova Larderello (20 MW), Radicondoli 2 (20 MW) and Chiusdino 1 (20 MW), in addition to the complete renewal of six 20 MW power plants. He was also involved in feasibility studies, basic engineering and authorization process for EGP projects in Italy and abroad (Chile, USA); ongoing is the construction design of the Bagnore 4 power plant (2 x 20 MW) in a water-dominated field in Mt. Amiata area. Dr. Sabatelli is author or co-author of many papers presented at the main international geothermal conferences.



Paola Bombarda

Lecturer, PhD, Politecnico di Milano, Italy
paola.bombarda@polimi.it

Paola Bombarda has a PhD in Energetics -1994 and MSc Degree in Mechanical Engineering - 1990, both from Politecnico di Milano (I) and is Assistant Professor of “Energy and Environmental Systems” at Politecnico di Milano since 1995. She has a deep knowledge in thermodynamic analysis of energy systems for power generation, cogeneration, trigeneration and plant performance optimization, with specific interest in renewables and above all in geothermal energy. She has gained wide experience in modeling, simulation, thermodynamic analysis and optimization of geothermal power plants (dry steam and flash, binary, hybrid plants) for which she also tackled techno-economic analysis and electric energy cost estimation. Particular expertise is acquired for ORC plants. Research activity is devoted also to the study and analysis of complex energy systems including geothermal heat pumps. Participant to several national and European research projects on geothermal energy and energy systems. Lecturer for the subject “Geothermal energy” in the frame of the master RIDEF at Politecnico di Milano. She contributed with papers and presentations to the main international geothermal Conferences.

Session III - Plant operation, energy supply and grid integration

F. Heilemann and S. Reith

Abstract

The integration of electricity from geothermal power plants into the electricity grid has to be seen from different perspectives. In the following the legal aspects and the function of the regulated energy market are explained as well as demand for geothermal power and the process, the costs and the legal background of grid integration. This gives the reader a broad understanding of the main foundations for grid integration of geothermal electricity. Based on regulated energy markets different legal systems in Europe support the integration of renewable power into the market, which is met by a growing demand for renewable power in general and geothermal power in particular. The growing share of renewable power causes problems in grid stability. That is why besides legal also technical requirements determine the process of grid integration. The costs for grid integration are very site specific and are determined by the network connection point and the installed capacity of the power plant.

Keywords: grid integration; costs of grid integration; energy market; electricity grid

Regulation and energy trade

Electricity supply has developed since its beginnings in the late 19th century in monopolistic structures. Because of expensive infrastructure and its associated economic advantages of a monopole, vertically integrated energy suppliers got the task of supplying the public and the industry with electricity.

With the electricity market directive 96/92/EG the European Union has changed this monopolistic market structure. The goal of this directive was free trade and competition on the electricity market (Konstantin, 2007, S. 37). Since then several other EU directives and decisions have brought European wide energy trade and the possibility for every customer to choose its electricity supplier. Part of this is the free access to the electricity grid. Several European and national political requirements like for example the so called unbundling, which means the legal separation of production, transport and distribution, shall give every user a fair, transparent and equal access to the electricity network (European Parliament and the Council, 2003, Art. 7-9).

In the liberalised energy markets, electricity became a trade product which is similar to shares or other commodities traded over a stock exchange or in bilateral contracts. Bilateral or the so called over-the-counter trade is a classical contract between two parties, which negotiate price, amount and time of delivered electricity. However, trading over the stock exchange works with standardized products. The products are characterized by the period of supply (hours or time periods) and are offered in €/MWh. As a reference for energy prices the spot-market is used. Here suppliers and buyers of electricity can put their offer and demand requests in an anonymous order book. At 12 o'clock the order book is closed for the

following day. Demand and offers are merged in a merit order, where the most expensive power plant which is needed to satisfy the demand sets the price.

Besides the free electricity trade, renewable electricity is in many countries supported by different federal programmes. With the Electricity Feed-in Act (StrEG) Germany started 1991 to support renewable energies with feed-in-tariffs and the legal obligation for grid operators to connect renewable capacity to the electricity grid (BRD, 1990). 2000 the “Renewable Energy Act (EEG)” has replaced this act and has introduced geothermal energy into the federal support mechanism. Similar regulations also exist in other European countries for example France. Since 2000 the “Loi n°2000-108” supports renewable energy sources (RES) with feed-in-tariffs, an obligation for the grid connection and special tenders for renewable energies (BMU, 2011).

Electricity Grid

The natural monopole of the electricity grid is strongly regulated. National regulation authorities monitor the discrimination free access and the cost efficient operation of the networks. The operators are paid for their effort by network-use fees. These fees at least have to be made public. In Germany the authority in charge approves them with a benchmark system, which takes among others the geographical differences into account (Konstantin, 2007).

The integrated European electricity grid enables a secure electricity supply in Europe by connecting numerous power plants. This redundancy leads on the one hand to a secure and efficient power supply; on the other hand long distances have to be bridged. The transported power is the key parameter for the network design. The power can be calculated with $P = U \cdot I \cdot \sqrt{3}$. As the current is limited by the heat resistance of the wire, the voltage is the only parameter, which can be adapted to the power demand. This fundamental law of electricity transport leads to the insight, that different network levels are necessary for different transport tasks.

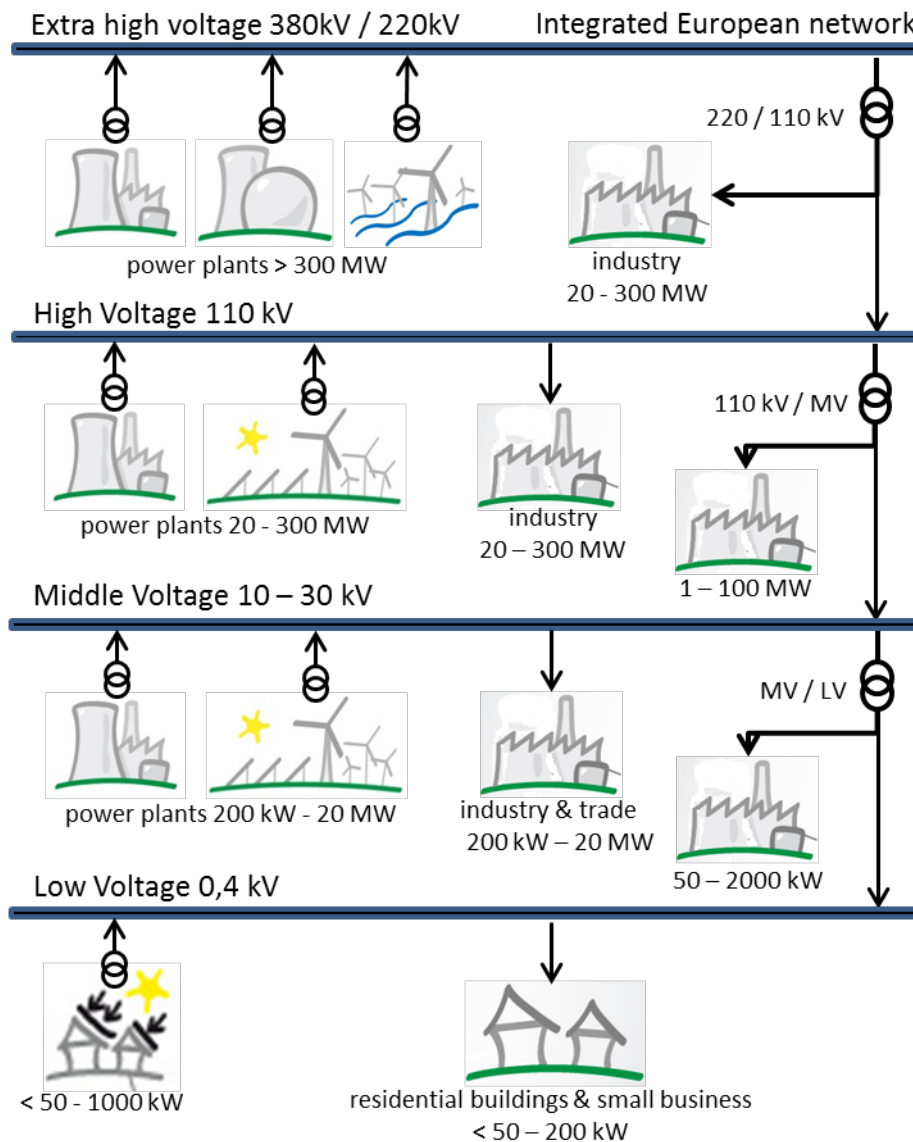

Figure 1. Schematic diagram integrated network (own illustration based on Konstantin, 2007, S. 330).

Figure 1 gives an overview of the different network levels. The electricity of big power plants (>300 MW) is fed into the extra high voltage grid. This grid level transports the electricity over long distances to consumption centres. The long distances make an extra high voltage of up to 380 kV necessary. Transformer stations transform the electricity to 110 kV (High Voltage). This level is used to distribute electricity to regional consumption centres or large industrial companies. The next step is to transform the electricity to the middle voltage level (10 – 30 kV), which supplies districts, bigger cities and industrial sites. Residential buildings and small businesses are finally connected to the grid by the low voltage level with 400V (Konstantin, 2007, S. 331).

Geothermal power plants (single power plants in a complex) in high enthalpy regions like Italy or Iceland deliver up to 750 MW or more. These power plants usually feed their electricity direct into the high or extra high voltage level. In low enthalpy areas like Germany

typical geothermal power plants have an installed capacity of 1 - 5 MW, which means that they are connected to the medium voltage grid.

Demand for geothermal power

The European Union has set itself ambitious goals for becoming a high-efficiency, low carbon economy. Until 2020 20% of the energy consumption shall be met with renewable energy. Additionally CO₂-emissions shall be cut by 20 % and the energy efficiency shall be increased by 20 % (European Commission, 2012). Geothermal energy is defined under German law as a renewable energy source and is needed to achieve these goals (BRD, 2012, § 3; 3). Geothermal electricity in Germany has a technical potential of nearly 300 TWh/a and can so contribute to renewable energy generation (Paschen, Oertel, & Grünwald, 2003). 300 TWh/a would be ~ 60 % of the annual German electricity demand (based on 2010) (BMW_i, 2012). Currently there are 10.7 GW_{el} of geothermal capacity installed worldwide. Germany has with 7.3 MW_{el} only a small share in this capacity. Until 2020 the German government predicts an installed capacity of ~ 200 MW_{el} while the German renewable Energy federation expects up to 470 MW_{el} (Geothermie Bundesverband). The high availability of geothermal power plants also contributes to the demand for geothermal energy. Geothermal power plants have one of the highest capacity factors¹ of all electricity production technologies. With ~ 90 % geothermal power plants have a capacity factor which is as high as the capacity factor of nuclear power plants (Tidball, Bluestein, Rodriguez, & Knoke, 2010). This makes geothermal power besides hydropower one of the only renewable power plants which are suitable for base load. Beside the electricity production it is possible to use geothermal power as a heat source for district heating. Geothermal power plants can so be used as combined heat and power source. This improves the efficiency of the power plant as well as the economic situation.

Grid integration of an increasing share of renewable power generation – challenges for the network and system operation

The European 20-20-20 energy and climate targets, particularly the enormous increase of renewable generation will have a huge impact on both, the transmission and the distribution network as well. This becomes not only a question of balancing the power according to the equilibrium of generation and consumption and therewith the frequency control from the viewpoint of the Transmission System Operator (TSO), but becomes even more challenging for the Distribution System Operator (DSO). He has to deal with local and regional reverse load flow conditions, voltage problems and the overloading of lines. This can be summarized in the task of managing the system in a secure and cost efficient manner.

How dramatic the future development could be, illustrates the situation in Germany. Currently the system peak load amounts to nearly 80.000 MW. To reach the intended target of a 35% share of renewables in 2020 the capacity of installed renewables alone will be as

¹ full-load ratio of a power station per annum

high as the maximum peak load. In addition the priority feed-in of RES, the volatility and the intermittent generation will cause substantial problems for system stability in the West European Interconnection² as well as supply problems in the local areas of the DSO where renewables are connected to the grid. To meet these challenges a massive grid expansion and a frequent use of balancing power are necessary, which is associated with considerable costs.

A paradigm shift in the sense that load follows generation is needed. The incorporation of the customer and the development of smart grids with highly complex, real time communication systems to adapt generation and consumption and to realize an optimal use of network assets in a secure and cost efficient manner will be inevitable. That'll lead to additional and new requirements for decentralized power plants based on renewable feeding. For the medium and high voltage levels it'll be necessary to implement a load and generation management system to be able to operate the system effectively while keeping the quality standards and to optimize the connection capacity for RES in case of given network assets.

Costs of grid integration

To ensure a secure and reliable network operation network operators have specified requirements for the network connections of RES. An additional boundary condition for the grid connection in Germany is the incentive regulation for DSOs, which was introduced by the Federal Network Agency (BNetzA). DSOs are obligated to connect power plants in total (costs for DSO and power plant operator (PPO)) as cost efficient as possible. The most important point in the question of cost allocation is the network connection point (NCP). Objectives and transparent criteria to determine the NCP are given by law and regulations. This point marks the border of property, the responsibility for assets and defines the cost allocation between the PPO and the DSO.

The costs for the grid integration of a power plant depend on the chosen NCP and the integrated power. The NCP is needed to define the length of the wire, the needed assets like transformation stations and other side conditions, while the integrated power defines the voltage level and the needed type of wire. A general forecast for the costs of grid integration is therefore not reliable.

² European transmission network



- EGS Power Plant Soultz-sous-Forêts: - One production well 5000 m (in operation)
 - 200 °C aquifer temperature
 - 2 injection wells (in operation)
 - Organic rankine cycle process with 1.5 MWel

Figure 2. The Soultz Project: Geothermal plant in the Upper Rhine Valley.

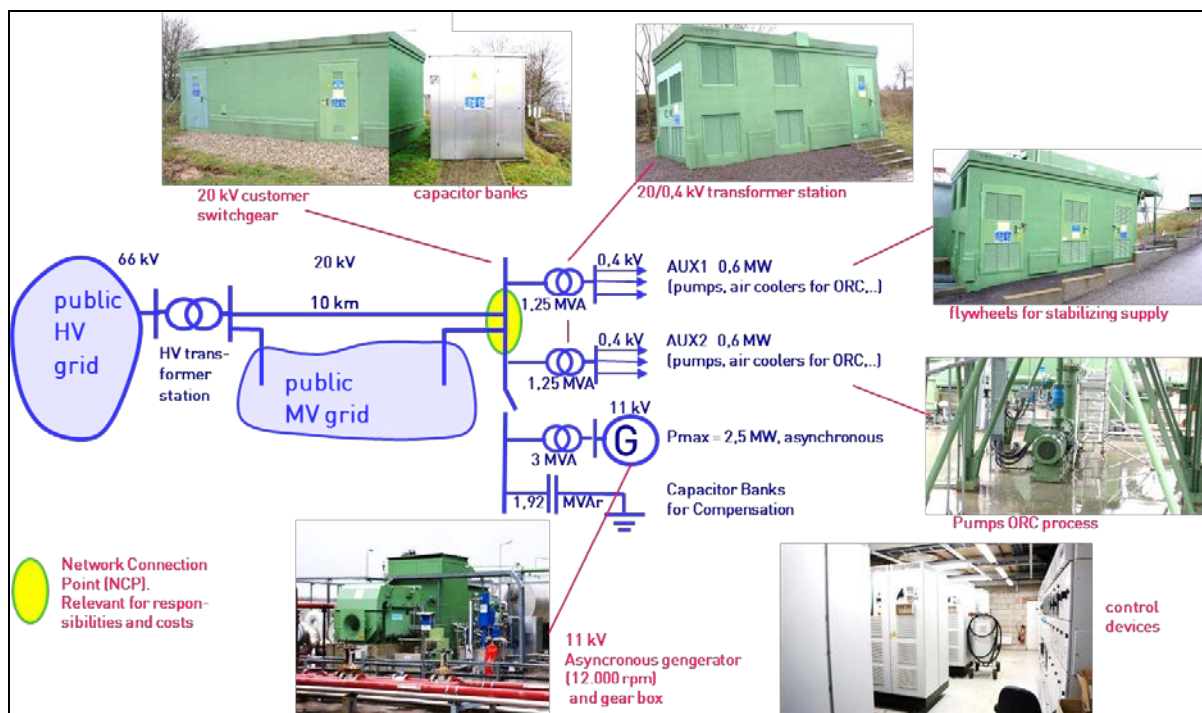

Figure 3. The Soultz Project. Electrical connection scheme and supply devices.

The integration of a power plant therefore has to be investigated site specific. As an example Figure 3 shows the connection scheme for the geothermal power plant in Soultz-sous-Forêts (France) (see Figure 2).

The connection to the public grid lies very close to the power plant so that routing costs could be kept to a minimum. The costs for the equipment obviously depend on the

requirements of the power plant. For the geothermal power plant in Soultz the costs of main parts of the electrical equipment are given in Table 1.

Table 1. Grid integration costs at the Soultz EGS power plant.

Generation	Transformer	46,000 €
	Switchgear	68,000 €
Auxiliaries	Transformer	93,000 €
	Switchgear	112,000 €
Compensation	Capacitor banks	24,000 €
Connection devices (general)	Medium voltage lines/cables	70 – 120 €/m
	Medium/low voltage substation	30,000 € - 50,000 €
	High/medium voltage transformer station	1 – 1.5 Mil. €

Process of grid integration

Basis for the determination of an appropriate NCP for the connection of the power plant is the information provided by the PPO. Criteria are the maximum real power P_{max} and the apparent power S_{max} of the plant as well as its location and the request for connection. This enables the DSO by means of network calculations to determine the appropriate NCP.

Usually the local network operator provides checklists, requirements, technical regulation and conditions for the connection and commissioning of the decentralized generation units. In this process the metering concept and the telecommunication devices also need to be specified. Construction and commissioning are rounding up the implementation. The PPO has to provide the conformity declaration to all these specifications. Figure 4 shows the process of grid integration in a flow diagram (BDEW, 2008; VDN, 2004).

In the process of grid connection, the PPO has to choose a model of remuneration. According to the law and regulations in Germany, PPOs can choose between three main models within the Renewable Energy Act (EEG).

1. “Normal” EEG remuneration (currently 25 Ct/kWh for geothermal power, according to §28 EEG).
2. Remuneration according to “Direct Marketing + Market Premium”
3. “Direct Marketing + Avoided Network Charges” model.

For the PPO the different models lead on the one hand to different income possibilities, which have to be calculated for every power plant individually. On the other hand the model selection leads to different contract partners. While in model one the remuneration is completely paid by the DSO, in model two and three the PPO sells its electricity on the free market (direct marketing) and gets an addition from the DSO. The DSO itself finances this

support for renewable energy by a levy for the electricity customer. The system is flexible and can be freely selected by the PPO each month if required (BRD, 2012).

In case of the limitation of the production due to the network operator’s constraints and system stability requirements, the plant operator is compensated by the DSO for the remuneration losses (BDEW, 2012; BNetzA, 2011).

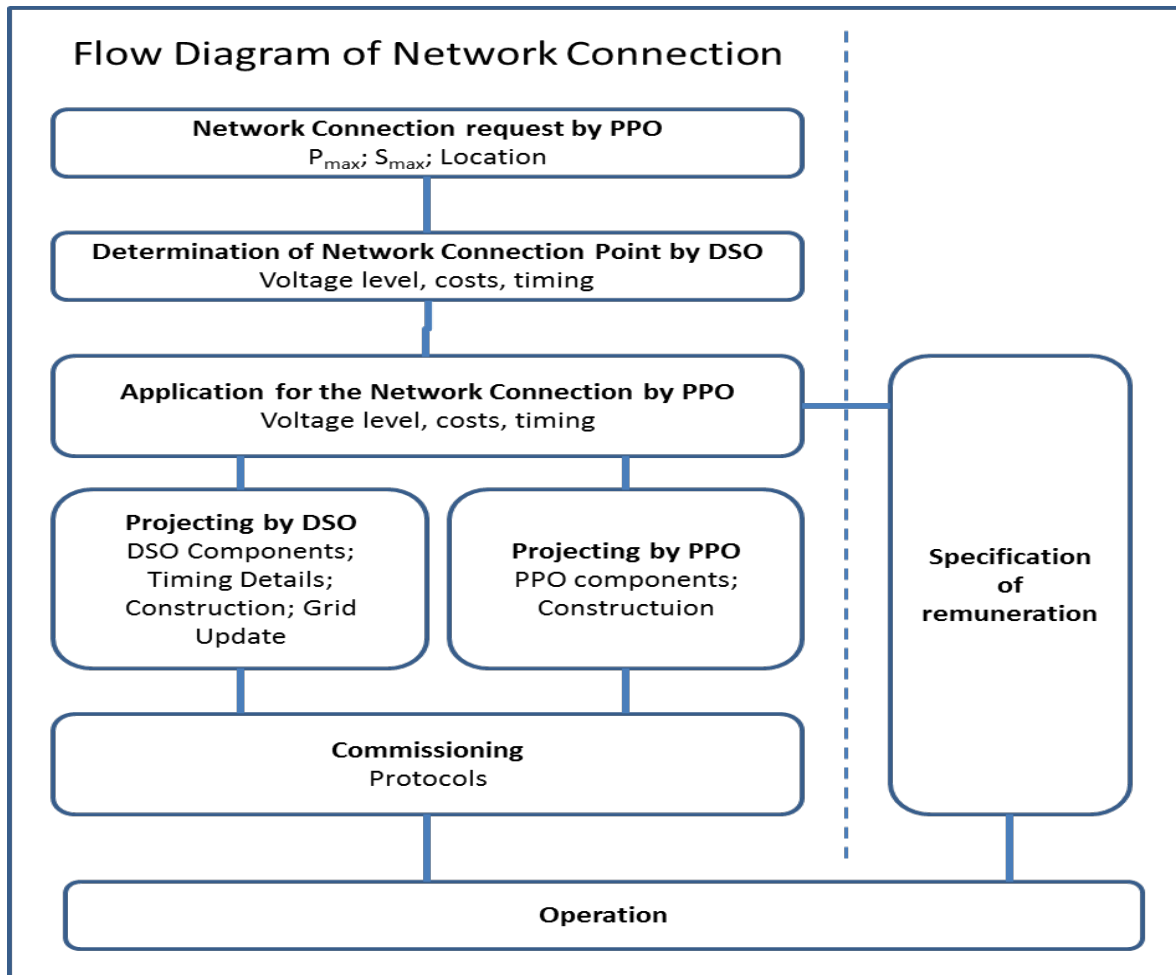

Figure 4. Flow diagram of grid integration (own illustration).

References

BDEW. (2012). *Ermittlung von Entschädigungszahlungen nach § 12 Abs. 1 EEG 2009*. Berlin: Bund deutscher Energiewirtschaft.

BDEW. (2008). *Technische Richtlinien Erzeugungsanlagen am Mittelspannungsnetz - Richtlinien für Anschluss und Parallelbetrieb von Erzeugungsanlagen am Mittelspannungsnetz*. Berlin: Bund deutscher Energiewirtschaft.

BMU. (2011, December 14). *Rechtsquellen erneuerbare Energien*. Retrieved September 28, 2012, from <http://www.res-legal.de/suche-nach-laendern/frankreich/mehr-zum-thema/land/frankreich/ueberblick/foerderung.html>

BMWi. (2012). *Energiedaten Deutschland*. Berlin: Bundesministerium für Wirtschaft und Technologie.

- BNetzA. (2011). Abschaltreihenfolge, Berechnung der Entschädigungszahlungen und Auswirkungen auf die Netzentgelte. Bonn: Federal Network Agency.*
- BRD. (2012). Erneuerbare Energien Gesetz (EEG). Berlin: Bundesrepublik Deutschland.*
- BRD. (1990). Gesetz über die Einspeisung von Strom aus erneuerbaren Energien in das öffentliche Netz. Bonn: Bundesrepublik Deutschland.*
- European Commission. (2012, September 10). Climate Action - The EU Climate and Energy Package. Retrieved September 27, 2012, from: http://ec.europa.eu/clima/policies/package/index_en.htm*
- European Parliament and the Council. (2003). EU - Directive 2003/54/EC. Brussels: European Parliament and the Council.*
- Geothermie Bundesverband. (n.d.). Geothermie in Zahlen. Retrieved October 05, 2012, from <http://www.geothermie.de/aktuelles/geothermie-in-zahlen.html>*
- Konstantin, P. (2007). Praxisbuch Energiewirtschaft. Stuttgart: Springer Verlag.*
- Paschen, H., Oertel, D., & Grünwald, R. (2003). Möglichkeiten geothermischer Stromerzeugung in Deutschland - Arbeitsbericht Nr. 84. Berlin: TAB Büro für Technikfolgen-Abschätzung beim Deutschen Bundestag.*
- Tidball, R., Bluestein, J., Rodriguez, N., & Knoke, S. (2010). Cost and Performance Assumptions for Modeling Electricity Generation Technologies. Fairfax: National renewable energy laboratory.*
- VDN. (2004). EEG-Erzeugungsanlagen am Hoch- und Mittelspannungsnetz - Leitfaden für Anschluss und Parallelbetrieb von Erzeugungsanlagen auf Basis erneuerbarer Energien an das Hoch- und Höchstspannungsnetz. Berlin: Verband deutscher Netzbetreiber.*

Session IV - Flash steam and binary technology

P. Bombarda and F. Sabatelli

Abstract

This is an overview of geothermal power generation with focus on flash and binary thermodynamic cycles, gathering systems and mechanical equipment used in power plants.

Flash steam cycles with single flash and double flash as well as different binary cycles (ORC and Kalina Cycle) are introduced and discussed. An overview of the design and optimization process of geothermal gathering systems and power plants with emphasis on particularities of the geothermal fluid is presented.

The presentation also focuses on features and mechanical design of the main equipment used in geothermal power plants, highlighting the different features and characteristics with respect to conventional fossil fuel steam plants.

Operation and maintenance of geothermal power plants with emphasis on the main equipment of the plant is introduced. Photographs of machinery in extreme conditions are presented and possible solutions are discussed.

Keywords: Geothermal energy, electricity generation, process flow, flash cycle, binary technology, steam gathering system, operation and maintenance

Process flow and steam gathering system

Geothermal power plants utilize heat energy from the Earth to generate electricity and can also be designed to generate combined heat and power (CHP). They are cost effective, reliable and environmentally friendly. The specific geothermal power plant configurations must match the heat resource to maximize its potential, but should also take into account a variety of other criteria, including local conditions and requirements as well as the needs of the local community. Thermodynamic cycles used in geothermal energy production will be reviewed: flash steam cycles with single flash and double flash as well as different binary cycles as ORC and Kalina Cycle are introduced and compared.

An overview of the possible schemes of steam gathering design (separators at wellhead, in satellite positions or at the power plant) with emphasis on two-phase flow considerations and design features is presented.

The steam field design includes situating wells drilled in groups as appropriate. Wells are preferably situated higher in the landscape than the separator station and power station. If possible the power station should be situated a little lower than the separator station. This is preferred to facilitate natural fluid flow. The distance between separation station and mist separators should be selected long enough for the moisture to condensate in the pipeline before entering the mist separators.

The parameters to be taken into account for the calculation of the optimum diameter of a pipeline will be discussed (pressure losses decrease and CapEx increase with pipe diameter increase), as well as insulation thickness.

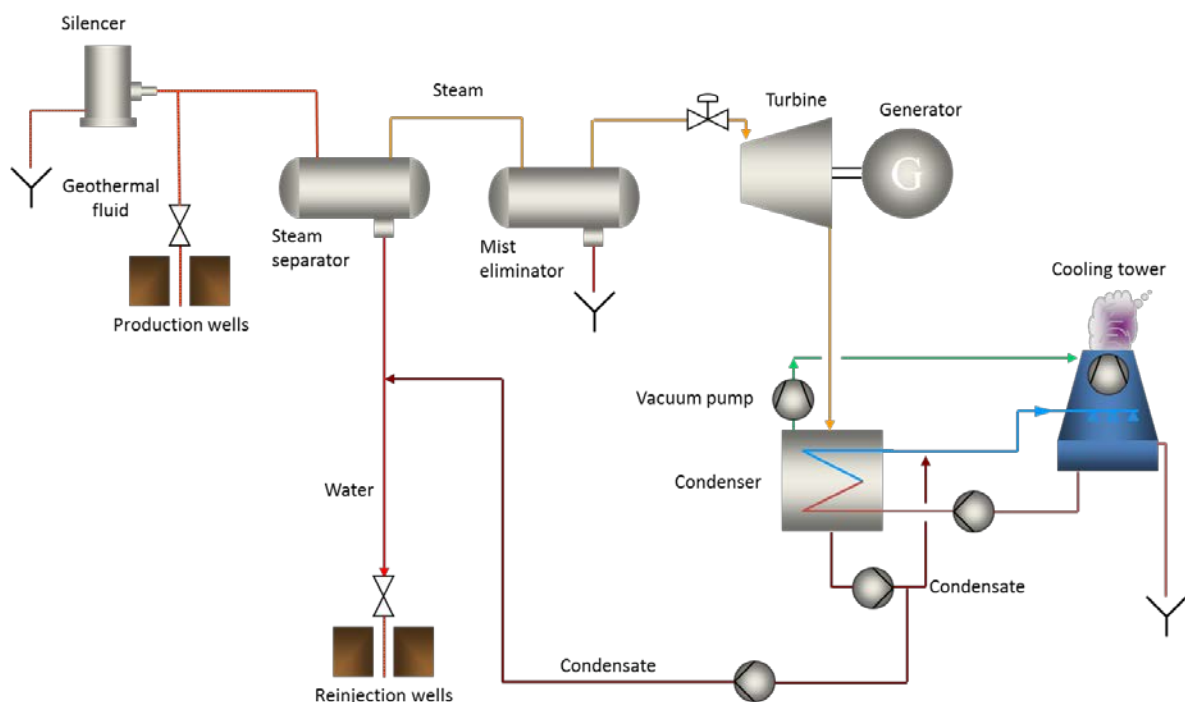

Figure 1. Process Flow Diagram of Steam Power Plant with Condenser.



Figure 2. Steam field and power plants in Piancastagnaio, Mt. Amiata area.

All geothermal fields are unique and the steam gathering system carries the energy from the field to the power plant. To join multiple wells into one steam gathering system requires for example decision of optimum separator pressure. Optimization requires balancing of technical and economical aspects: the optimum separator pressure can be calculated from a thermodynamic standpoint (maximizing the generated power output), but cost considerations (CapEx of the power plant increase at decreasing steam pressure) and other constraints often dictate pressure increase above the optimum.

When the geothermal fluid is two phase, and steam represents a low fraction of it, or the geothermal fluid is fully constituted by water, typically with medium-low temperature sources, the binary technology is applied, and generally a downhole pump (i.e. a pump installed directly in the well) is required. The geothermal fluid loop is in this case completely separated from the power generation cycle; the adoption of the downhole pump, though requiring a high auxiliary power consumption, can assure a constant discharge flow at a convenient pressure, so as to keep the geothermal fluid in liquid phase, avoiding any flash process. In this way two important results are obtained: all the non-condensable gases (mostly CO_2) are maintained in the liquid phase, and, salt precipitation, which could otherwise occur after the flash process, both downhole and on surface, is strongly reduced. Geothermal fluid leakage can be effectively avoided, because the fluid is confined in a

limited part of the plant, and total reinjection is then feasible, thus leading to a virtual zero emission plant and sustainable reservoir exploitation.

The power generation cycle is a closed cycle, whose design guidelines relies on fundamental thermodynamic principles, and it is realized by means of a convenient working fluid. The easiest possible scheme is shown in Figure 3.

The working fluid evaporation occurs in the evaporator, the heat exchanger charged with heat introduction; the vapour so generated enters afterwards the turbine, which is charged with power generation; subsequently the vapour condenses in the condenser, the heat exchanger charged with heat rejection to the ambient, and finally the condensate enters into the pump, which is charged with working fluid pressurization.

The working fluid selection is a crucial choice: being the cycle closed, whatever working fluid can be selected, but this choice has a huge effect on plant performance and component size, and thus cost.

The two different categories of binary cycles commonly available, Organic Rankine Cycles (ORC) and Kalina cycles, differentiate as far as the working fluid is concerned: in ORC a pure working fluid, (or seldom an azeotropic mixture) is utilized, while in Kalina cycle and Kalina derived cycles, a mixture of water and ammonia is selected.

At present, most commonly used working fluids for ORC geothermal applications are some hydrocarbons and refrigerants (several refrigerants are non flammable or flammable only under extreme ignition conditions, and are therefore particularly eligible when non-flammability is desired; other fluids, like siloxanes, may be selected at higher temperatures, as, for example, for biomass applications). As a first, general rule of thumb, the working fluid must be selected according to its critical temperature and the temperature of the geothermal source.

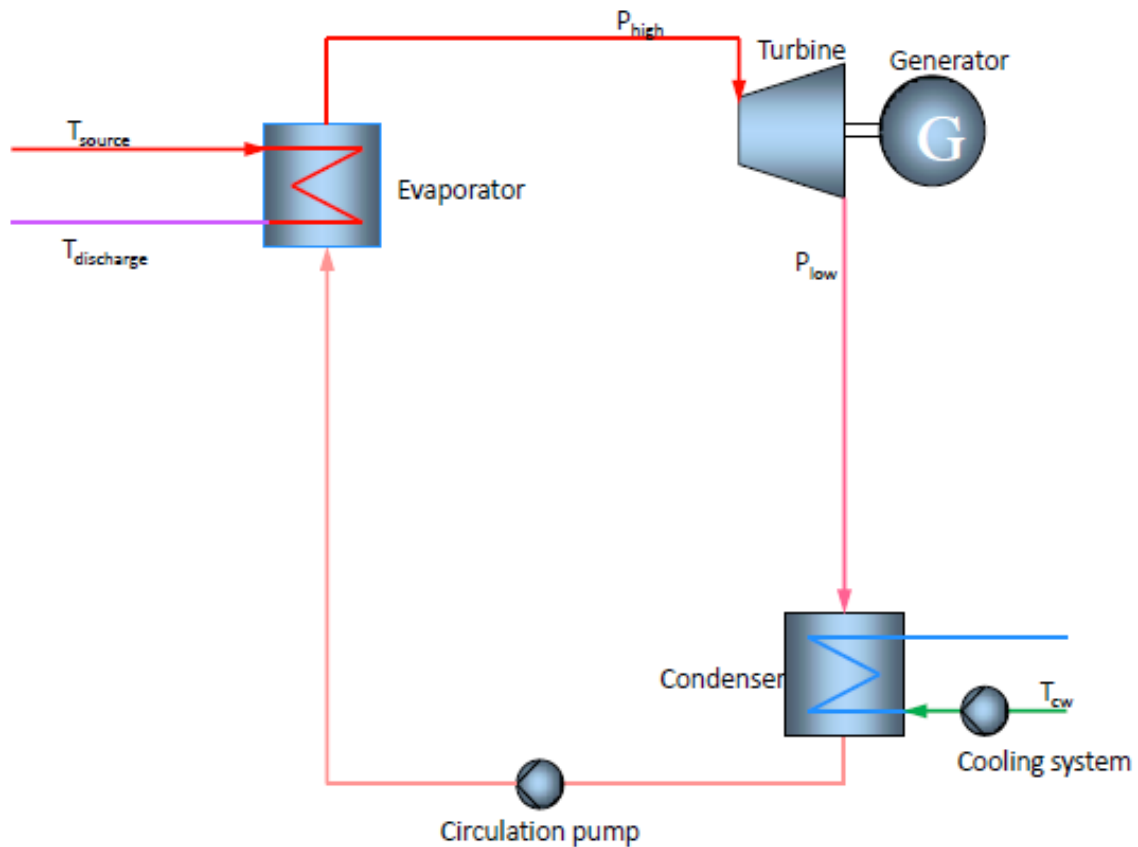

Figure 3. Binary plant scheme.

The heat introduction process, which implies the working fluid phase change, has a high influence on the cycle efficiency: with a pure (or azeotropic) fluid the phase change process in subcritical conditions is at constant temperature and pressure (Figure 4, top, left), with a mixture, instead, the phase change process occurs at constant pressure and variable temperature (Figure 4, top, right). If the hot thermal source is a variable temperature heat source, (which is the case for the geothermal source) a phase change process at variable temperature can better match the geothermal source, as shown in Figure 4; it can also be noted from Figure 4 that heat introduction at variable temperature is also obtainable by means of a cycle with pure fluid, multiple pressure evaporation (Figure 4, bottom, left) or supercritical cycle (Figure 4, bottom, right).

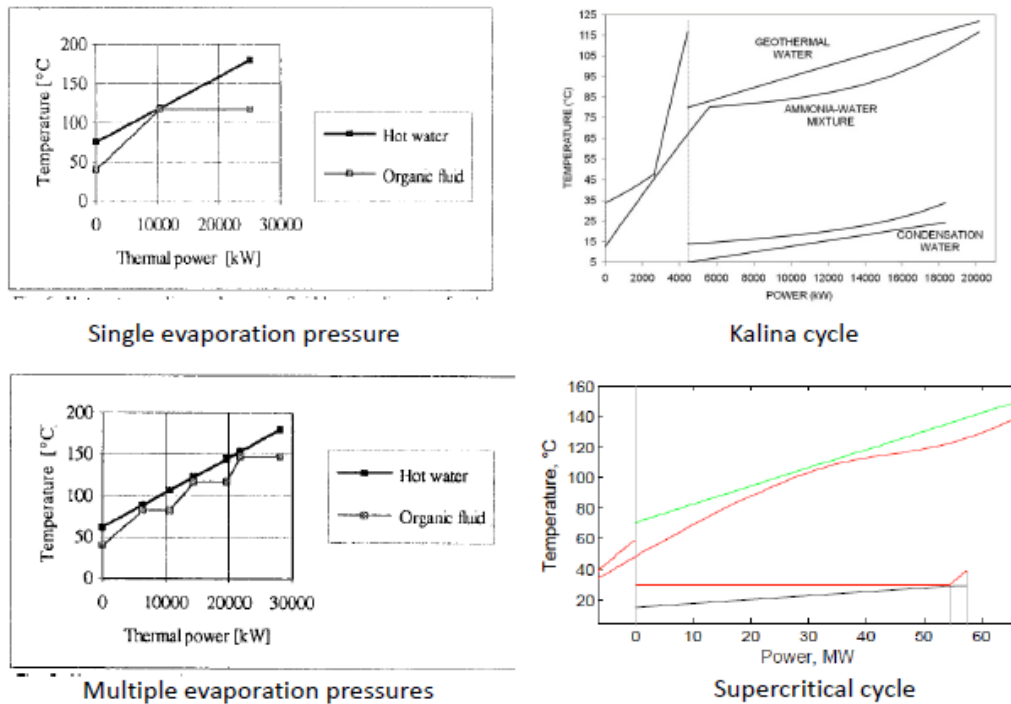

Figure 4. Heat introduction process in case of a) pure fluid b) mixture, c) pure fluid, multiple evaporation pressure, d) pure fluid, supercritical pressure.

Most of the existing geothermal binary plants are ORC with single pressure evaporation, but all the technical options shown in Figure 4 are available on the market; high efficiency plant configurations will be of great interest in the future, above all in Europe (techno-economic optimization with high drilling cost leads in fact to high binary plant specific cost, in order to fully exploit the source).

In order to give the best possible performance, the selected thermodynamic cycle need to be optimized, also taking into account scaling hazard, which may limit the cooling of the geothermal fluid. Need for an optimization process can be understood e.g. referring to the single evaporation pressure cycle: a too high evaporation pressure would lead to a high cycle efficiency but also to a poor heat introduction in the cycle, and vice versa for a too low evaporation pressure.

In some cases the cycle efficiency may be improved by means of an internal heat transfer, occurring in a recuperator. (Figure 5); this happens when the working fluid is such that the end point of the expansion process falls into the superheated vapour region, and therefore the vapour can be profitably cooled (thus heating the liquid coming from the pump) prior to enter the condenser.

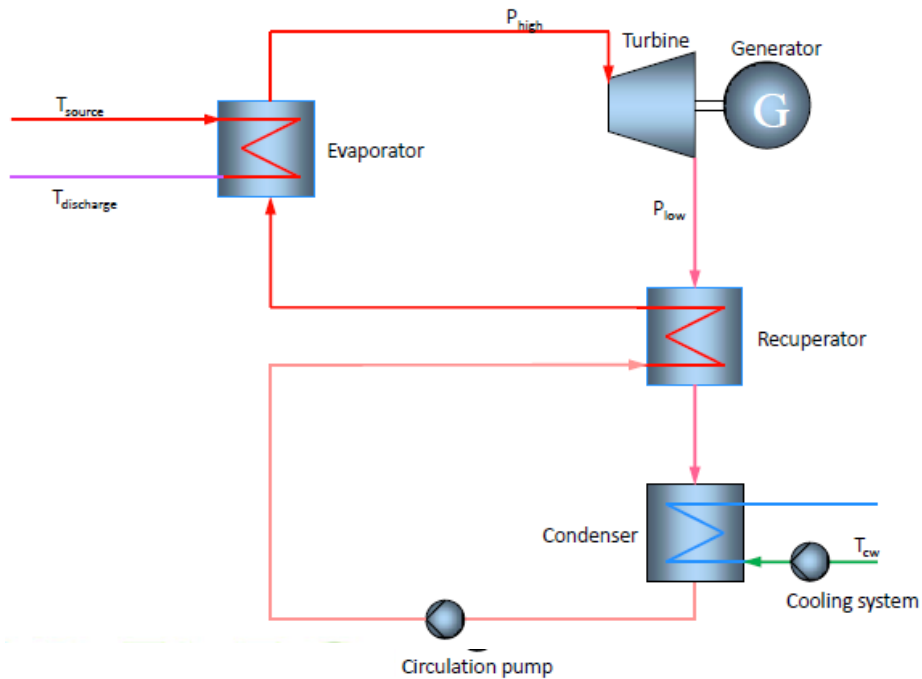

Figure 5. Binary plant with recuperation.

When using a mixture as working fluid, i.e. with Kalina cycles, the composition may be changed throughout the plant with the aid of separators and mixers (Figure 6); several recuperators (heat exchangers charged with internal heat transfer) could also be appropriate; as a result, different plant schemes exist and some of them are quite complicated.

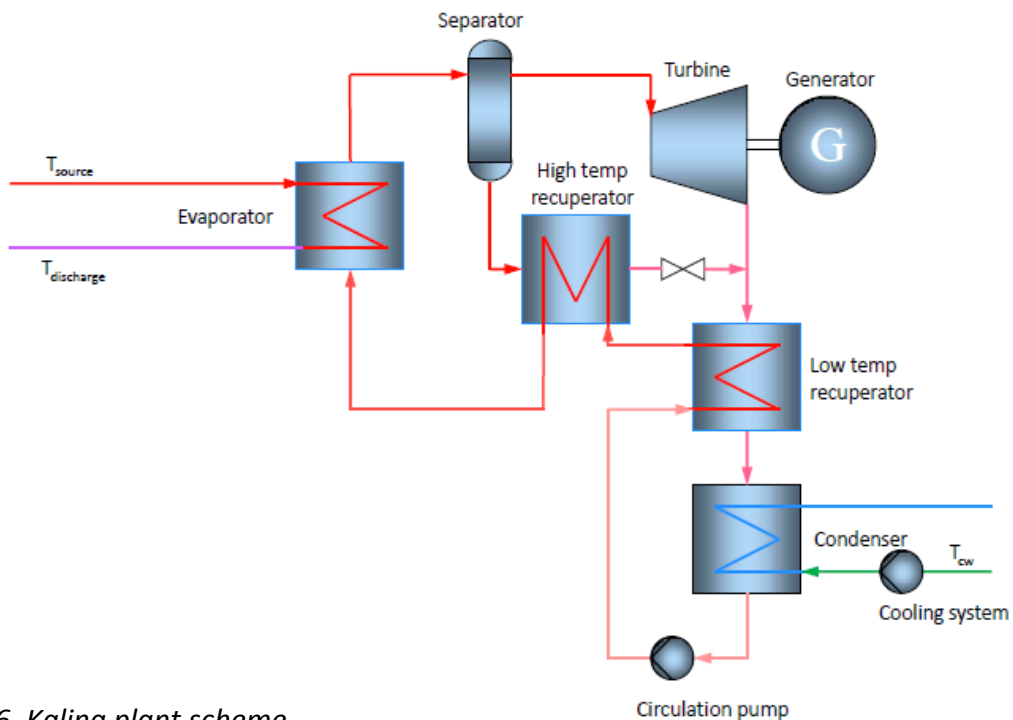

Figure 6. Kalina plant scheme.

The cycle efficiency depends on (i) geothermal source and ambient conditions and (ii) cycle design features: the influence of the geothermal source and ambient conditions can be understood recalling that for the reference ideal cycle holds

$$\eta = 1 - \frac{T_{amb}}{(T_{geoth,source} - T_{reinjection}) \ln\left(\frac{T_{geoth,source}}{T_{reinjection}}\right)}$$

The ambient temperature is variable according to the site, but in a rather limited range, while the geothermal source temperature may have a larger variation: as a matter of facts (Figure 7), existing binary plant efficiencies are comprised between 0.05 and 0.15; higher efficiencies are expected for plants fed by higher temperature geothermal sources.

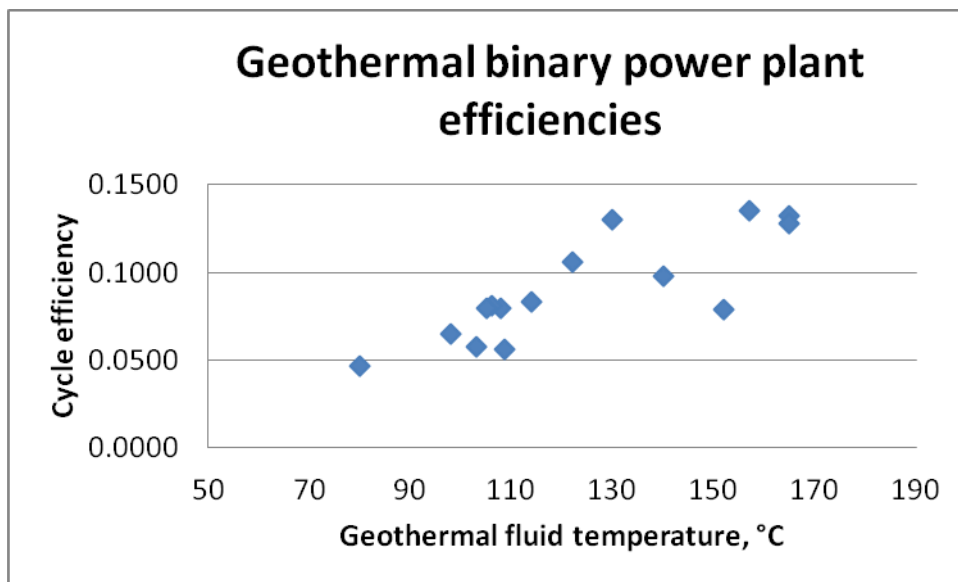

Figure 7. Binary plant efficiencies.

Plant balance must be finally evaluated, deducting auxiliary consumption (mainly downhole pump and, if not already considered, cooling auxiliaries) from the calculated net cycle power.

Finally, in case the geothermal source is two phase, with a relevant fraction of steam, the highest geothermal source exploitation is typically obtained by means of a plant which comprises a steam section and one or more binary sections (fig. 8); however, a simpler and different solution, based on the adoption of only the binary cycle is also eligible. In this case the steam fraction of the geothermal fluid is sent after the separator to the evaporator, and exploited to vaporize the working fluid of the binary cycle; the condensate is then recovered, mixed with the brine and sent to the preheater, in order to preheat the cycle working fluid prior to evaporation.

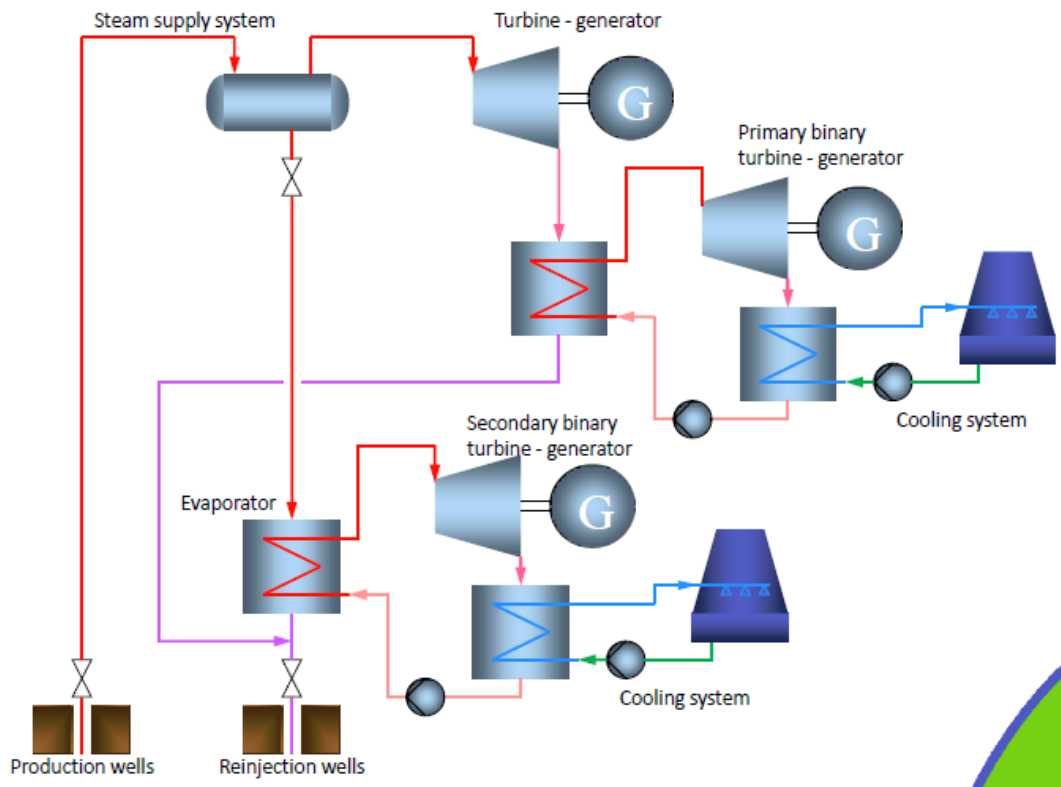

Figure 8. Mixed steam/binary plant.

Cascade use / cogeneration schemes are also feasible, as well as hybrid plants using the geothermal source in addition to another thermal source (e.g. solar or biomass or wastes).

Mechanical equipment and operation and maintenance

Mechanical equipment used in geothermal power plants are proven traditional equipment adjusted to the geothermal fluids. Emphasis within the course will be on different design considerations compared to conventional steam plants such as geothermal turbine sizes and control solutions at turbine inlet connected to operation and changes with time of the geothermal steam field. Flexibility of the equipment is of paramount importance, in order to cope with reservoir evolution while maintaining the highest efficiency.

Choice of material for geothermal turbines has to be adjusted to the available steam and is therefore different from material in traditional steam turbines. Non-condensable gases must be considered and removed from the condenser by means of a proper system since they would otherwise accumulate in the condenser. The steam entering the turbine is saturated and therefore, the steam starts to condense in the turbine. As a result droplets form in the flow and the droplets wear down the turbine blades. To decrease the amount of droplets in the flow, it is important to carefully design lead ways for the condensate in the turbine. Scaling may also occur, especially at the first-stage nozzle nearest the turbine inlet leading to reduced generator output. Scaling can impact the effectiveness of the guide vanes. Scaling is removed during regular turbine maintenance.

The main features of the machinery installed in geothermal power plants (impulse and reaction turbines, condensers) with sketches and photographs of real equipment, as well as the possible schemes of non-condensable gas extraction and heat rejection to the environment will be presented, highlighting the pros and cons of different solutions.

The main issues of operation and maintenance of geothermal power plants (scaling, various forms of corrosion, etc.) are discussed, showing photographs of equipment damaged by ineffective design or extreme operating conditions, and presenting a short analysis of possible solutions.



Figure 9. Machine hall of Chiusdino 1 power plant, Travale-Radicondoli area.



Figure 10. Erosion of turbine mobile and fixed blades.

A binary plant consists of several heat exchangers, a multistage centrifugal pump and a turbine.

Different kind of heat exchangers (e.g. shell & tube, plate) are eligible. Depending on the flow specific conditions, possible corrosion on the side of the geothermal fluid oblige to adopt special and costly materials for the heat exchangers charged with heat introduction in the cycle, with a great influence on the cost of the unit, and possible scaling and fouling require removable covers and straight cleanable tubes.

The pump is usually operated at variable speed, so that greater flexibility and efficiency are achieved.

Axial flow turbines are most widely used in ORC plants: organic fluids exhibit usually low enthalpy drop during expansion, and a small single stage turbine, (or, if needed, a few stages turbine) is commonly appropriate. Axial flow turbines are often directly coupled to the electric generator, and therefore rotate at 3000 rpm or 1500 rpm (1800 in the US); otherwise they are provided with a reduction gear, or, in a few cases faster and smaller turbines (coupled to a variable speed electric generator) have also been employed. The adoption of radial turbines has also been proposed: it must be pointed out that both radial inflow and radial outflow turbines have been considered. The radial inflow scheme allows larger work per stage and moreover, partial admission vanes can be easily accommodated;

radial outflow scheme consents a small work per stage (several stages are then needed) but tolerates high variations of the volumetric flow between the inlet and outlet of the turbine.

Most of the problems encountered with steam turbine are not present with binary turbines: in ORC plants, the selected working fluid is not chemically aggressive, and it is usually such that the expansion ends in the superheated vapor region, thus preventing the turbine blades from droplets erosion; moreover the turbine is subjected to low mechanical stress due to the low peripheral speed. In Kalina cycle based plants, the working fluid is toxic and corrosive, and particular attention is to be paid for possible leakages. As a whole, limited O&M requirements and long life are typical for binary plants.

Relevant Publications

- Allegrini G. and Sabatelli F. (1989); "Thermodynamical analysis of the optimum exploitation of a water-denominated geothermal field with high gas content." Seminar on New Developments in Geothermal Energy - Ankara (Turkey), 22-25 May 1989.*
- Andreussi P., Minervini A., Paglianti A. and Sabatelli F. (1994); "Two-phase flow of brine in long pipelines: analysis of field experiments." Geothermics 23, 33-41.*
- Angelino G., Bini R., Bombarda P., Gaia M., Girardi P., Lucchi P., Macchi E., Rognoni M., Sabatelli F., "One MW binary cycle turbogenerator module made in Europe", " World Geothermal Congress", Firenze, 1995.*
- Annoni F., Mattacchini F., Sabatelli F., Tognotti L. and Zanelli S. (1995); "Wet-dry cooling alternatives for geothermal power plants." Proc. of the World Geothermal Congress 1995, 1899-1903.*
- Bombarda, P., "Combined, Mixed and Binary cycles for electricity Generation from Geothermal Sources - part B: technical economic analysis ", Proceedings of "The 20th New Zealand Geothermal Workshop", pp. 353-358, Geothermal Institute, The University of Auckland, 11-13 novembre 1998, Nuova Zelanda ISBN 0-86869-083-X. "Best Engineering Paper".*
- Bombarda, P. Macchi, E., "Optimum cycle for geothermal power plants", Proceedings of the "World Geothermal Congress 2000", pag. 3133-3138, Tokyo 2000.*
- Bombarda, P., Gaia M., "Binary Systems with Geothermal Fluid Pressurization to Avoid Flashing: Energy Evaluation of Down-Hole Pump Cooling Below Geothermal Fluid Temperature" Proceedings of the "World Geothermal Congress 2005, Antalya, Turchia, 2005.*
- Bombarda, P., Gaia M., "Geothermal Binary Plants Utilising an Innovative Non-Flammable Azeotropic Mixture as Working Fluid" Proceedings of 28th NZ Geothermal Workshop - New Zealand, novembre 2006.*
- Bombarda, P., Gaia, M., Pietra, C., "Integration of Geothermal Liquid Dominated Sources and Waste Heat Sources for Electricity Production", Proceedings of the "World Geothermal Congress 2010, Bali, Indonesia.*
- Bombarda, P., Duvia, A., Macchi, E., "Combined, Mixed and Binary cycles for electricity Generation from Geothermal Sources - part A: selected configurations and calculation*

- model", Proceedings of "The 20th New Zealand Geothermal Workshop", pp. 347-352, ", Geothermal Institute, The University of Auckland, 1998, Nuova Zelanda ISBN 0-86869-083-X.*
- Bonciari R., Lenzi A., Luperini F. and Sabatelli F. (2013); "Geothermal Power Plants in Italy: Increasing the Environmental Compliance." European Geothermal Congress, Pisa 3-7 June 2013. Hallgrímsdóttir E., Ballzus C. and Hrólfsson H. (2012); "The Hellisheiði Power Plant, Iceland." GRC transaction, Volume 36, page 1067–1072.*
- Corsi R., Culivicchi G. and Sabatelli F. (1985); "Laboratory and field testing of calcium carbonate scale inhibitors." GRC Trans. 9, 239-244.*
- Pieri S., Sabatelli F. and Tarquini B. (1989); "Field testing results of downhole scale inhibitor injection." Geothermics 18, 249-257.*
- Sabatelli F. and Mannari M. (1995); "Latera development update." Proc. of the World Geothermal Congress 1995, 1785-1789.*
- Sabatelli F., Mannari M. and Parri R. (2009); "Hydrogen sulfide and mercury abatement: development and successful operation of AMIS technology." GRC Trans. 33, 343-347.*

Day 3 - 10 October 2013

Presenters

C. Karytsas, D. Mendrinou, F. Batini, F. Jaudin, R. Kutschick, R. Barontini, M. Borzoni, F. Rizzi and I. Nardini.

Curricula vitae



Constantine Karytsas

Dr., Deputy Dir. of RES Division
kkari@cres.gr

Dr. Constantine Karytsas has a PhD degree in Geology-Energy from Pennsylvania State University (PSU) USA -1992, and a MSc degree in Environmental Geochemistry from the University of Newcastle Upon Tyne (UK) (1984) with over 20 years professional experience in geothermal applications. Recent work amongst others includes the fields of Seawater Desalination, ORC Binary Cycle Power Production, Geothermal Direct Heat Applications, Geothermal Heat Pump Research and Demonstration, and innovative COMBI system Solar Energy Applications. Participation in 80 research and application/demonstration projects (coordinator in 20 of them) funded by the EU, the European Industry, the Greek State and the Government of the United States (Departments of Energy and Environment). Dr. C. Karytsas is the author or co-author of more than 18 peer reviewed journal articles and 60 announcements in the proceedings of international conferences.

Served as: Deputy Director of RES division, CRES (2010 – today); Head of the Geothermal Department of CRES (1989-2010); Lecturer on Geothermal Applications at Technical University of Crete (since 1994) and National Technical University of Athens – NTUA (2004).



Dimitrios Mendrinou

MEng, MBA, Senior Geothermal Eng.
dmendrin@cres.gr
Centre for Renewable Energy Sources
and Saving, (CRES), Greece
dmendrin@cres.gr

Dimitrios Mendrinou is a geothermal engineer with masters degree in geothermal energy from the University of Auckland, New Zealand, MBA from the University of Surrey, UK, and more than 20 years professional experience in geothermal energy matters. His recent work includes R&D and market development projects on geothermal heat and power (planning, design and management of geothermal field exploration, exploitation, production monitoring, reservoir engineering and power generation) and ground source heat pumps. He has been the coordinator of the GROUND-REACH and GROUND-MED European projects, and Technical Manager of the GROUNDHIT and LOW-BIN

European projects. In addition, he has more than 15 publications in international journals plus 35 announcements in international conferences related to geothermal energy.

Served at: Geothermal Energy Department at CRES (2003-today), North Greece Office of CRES (2000-2003). Omega European Consulting Ltd, Kapa Systems, Geothermiki Ellados and others (1993 – 2000). LDK Consultants, Engineers & Planners (1990 – 1992). Lecturer at the Technical Educational Institute (TEI) of Piraeus – Fluid Mechanics Laboratory (1990-2000).



Dr. Fausto Batini
Managing Director
Magma Energy Italia s.r.l.
fbatini@magmaenergycorp.com

Dr. Fausto BATINI graduated in Geology at the University of Florence in 1975, subsequently enriching his knowledge on geothermal with the Postgraduate Course in Geothermal Energy in 1976 at the International Institute for Geothermal Research in Pisa.

From 1976 to 2008 he worked in the geothermal energy sector at ENEL covering various roles over time: he started in the field of research and application of innovative technologies for exploration, then moved to management of operations for well logging and testing, environmental monitoring and chemical-physical analysis. Then he took the lead of Exploration Task Force managing several projects in Italy and abroad.

Since 2003, he was assigned to the International Division where he held the role of Manager for Geothermal Business Development worldwide then served as Director in the board of Empresa Nacional de Geotermia s.a. in Chile and as Vice President of Enel Geothermal L.L.C. in North America, where he managed the geothermal program including the construction of two binary cycle power plants.

In 2009 he joined the Centre of Excellence for Geothermal Energy in Larderello as Technical Director and served as Coordinator of Joint Program on Geothermal of Energy launched by European Energy Research Alliance in the framework of EU Strategic Energy Technology Plan. Since May 2010 he serves as Managing Director of Magma Energy s.r.l. Italy, a subsidiary of Alterra Power Corporation.



Florence Jaudin
PhD. in Hydrogeology, geochemistry,
mineral and energetic resources
prospecting
Project Manager
Bureau de Recherches Géologiques et
Minières (BRGM), France
f.jaudin@brgm.fr

Dr. Florence Jaudin, active since 1985, in BRGM, in managing, analysing and diffusion of technical and scientific data on geothermal energy at national level. She also contributed in promoting geothermal energy through several national and international associations, and

has also been involved in several training operations supported by French institutions and European Community. From 2004, she coordinates the BRGM contribution on several European projects on geothermal energy (GEOFAR, GEOTRAINET, GTR-H, GROUND-REACH, LOW-BIN, etc.) she is also involved in several French geothermal training programs.

	<p>Robert Kutschick Lawyer Groth, Siederer & Coll. (GGSC), Germany Kutschick@GGSC.de</p>
---	---

Robert Kutschick studied law in Leipzig.

Legal clerkship at the District Court of Leipzig (Landgericht), e.g. station in Rio de Janeiro (law firm Stüssi Neves Advogados). Admitted in 2012 to the Munich Bar Association, and since then lawyer at [GGSC].

Area of work: energy and climate change, water management, municipal services

Action priorities: Geothermal (Procurement and Contracting, corporate law, feed-in tariffs), water (antitrust), infrastructure (fiber optic cable, district heating).

Articles, essays and lectures on legal aspects of geothermal energy

	<p>Roberto Barontini Professor of Corporate Finance Management Institute Scuola Superiore Sant'Anna, Italy r.barontini@sssup.it</p>
---	--

Roberto Barontini, PhD, is professor of at Scuola Superiore Sant'Anna in Pisa (Italy) and director of the Masters' Course in Innovation, Management and Service Engineering (MAINS). He has a long-standing teaching experience in the fields of Corporate Finance and Financial Analysis. He actually teaches the course "Finance of Innovation" at University of Pisa and teaches in many master's courses. He is scientific director of the "Credit Risk Management" program, ABI Formazione. His research is currently focused on investments, corporate governance, risk management, and innovation financing.



Matteo Borzoni
Ph.D. on Sustainability Appraisal
Management Institute
Scuola Superiore Sant’Anna, Italy
m.borzoni@sssup

Matteo Borzoni has had a varied career in development, training and research in a range of countries, with a primary focus on Latin America, Africa and Italy. He has an interdisciplinary background acquired through a degree in agriculture from the University of Florence, an M.Sc. in rural development from Imperial College London and a PhD from Scuola Superiore Sant’Anna in sustainability appraisal with a specific focus on renewable energy. Currently he also works as a free-lance consultant.



Francesco Rizzi
Researcher
Management Institute
Scuola Superiore Sant’Anna, Italy
rizzi@sssup.it

Francesco Rizzi graduated cum laude at University of Pisa in Civil Engineering. Holds a Master Degree in Environmental Management and Control at Scuola Superiore Sant’Anna in Pisa, Italy. Since 2003 he is a member of the research team on sustainability of Scuola Superiore Sant’Anna, where he coordinates national and international projects in field of corporate management of resource efficiency and is assistant professor of Management. Among his research interests are the entrepreneurial dynamics in smart communities, the analysis of inter-organizational strategies for sustainability under an evolutionary perspective, the management of adaptation and mitigation strategies for climate change. He pays particular attention to energy, waste sectors as relevant research settings. He is lecturer in several master programmes in the field of innovation and green management. Since 2006 is partner and project manager in ERGO, an University Spin Off that provides services to transfer research outcomes in field of environmental management to operational levels. He is member of the management board of the COST TU1204 Action “People friendly city in a data reach world”. He is member of the Board of the only Italian geothermal district heating service provider. He has expertise as advisor to several public authorities and industrial organisations for energy and waste management. He is expert evaluator for the European Commission for FP7 and FSE programmes in field of environmental management.



Isabella Nardini
Ph.D. in Geochemistry and Petrology
National Research Council of Italy, CNR
nardini@igg.cnr.it
(for CV see Session I – Geothermal
Exploration)

Session V - Market aspects

C. Karytsas and D. Mendrinis

Abstract

Geothermal resources of Europe can contribute to the EU targets of 20% less greenhouse gas emissions, 20% RES share and 20% more energy efficiency by 2020. The session provides an overview of the present status and future prospects of global geothermal electricity market niche, including market size (turnover, capacities, energy yields), near term growth, quality of resources, technologies employed, key players, investment and electricity generation costs, market barriers and incentives.

Keywords: geothermal, power plants, resources, market, development, costs

International Geothermal Market overview

Geothermal energy is the heat of the earth. Depending on the geological environment they are encountered in, geothermal resources are characterized as magmatic/volcanic systems, thermal aquifers, geopressured basins and crustal heat. A global geothermal resource estimate of above categories, in comparison to fossil fuel reserves, is presented in Table 1.

Table 1. World geothermal resources compared to global fossil fuel reserves.

Geothermal resources	billion TOE	Fossil fuel reserves (end 2011)	billion TOE
Crustal heat	10.775.600	Coal	422
Magmatic/Volcanic	327.360	Oil	234
Geopressured	55.924	Natural gas	188
Aquifers, thermal	18		

Geothermal exploitation technology requires drilling one or more production wells delivering subsurface hot fluids to the surface, which after feeding a geothermal power plant, are injected back to their origin formations through reinjection wells. In that case, e.g. when deep hot fluids are available, the geothermal resource is termed as a hydrothermal system. Almost all geothermal power plants today are located in such hydrothermal systems, which are encountered mainly at the boundaries of tectonic plates and at geological hot spots, where hot magma is rising towards a thin earth crust. Location of geothermal power plants is shown in Figure 1.

The geothermal plant at Soultz, proved that the exploitation of other parts of the earth crust, where deep hot formations do not naturally deliver the necessary amounts of fluids, is also technically feasible. In these geologic conditions, the hot rocks are artificially fractured by hydraulic fracturing, acidizing, propellants, etc., in order to engineer a man made reservoir, through which surface water is circulated serving as the heat transfer media. These are termed as enhanced geothermal systems (EGS). At present only a few EGS plants

are in operation or under development around the globe, but future large scale exploitation of geothermal energy lies in this technology.

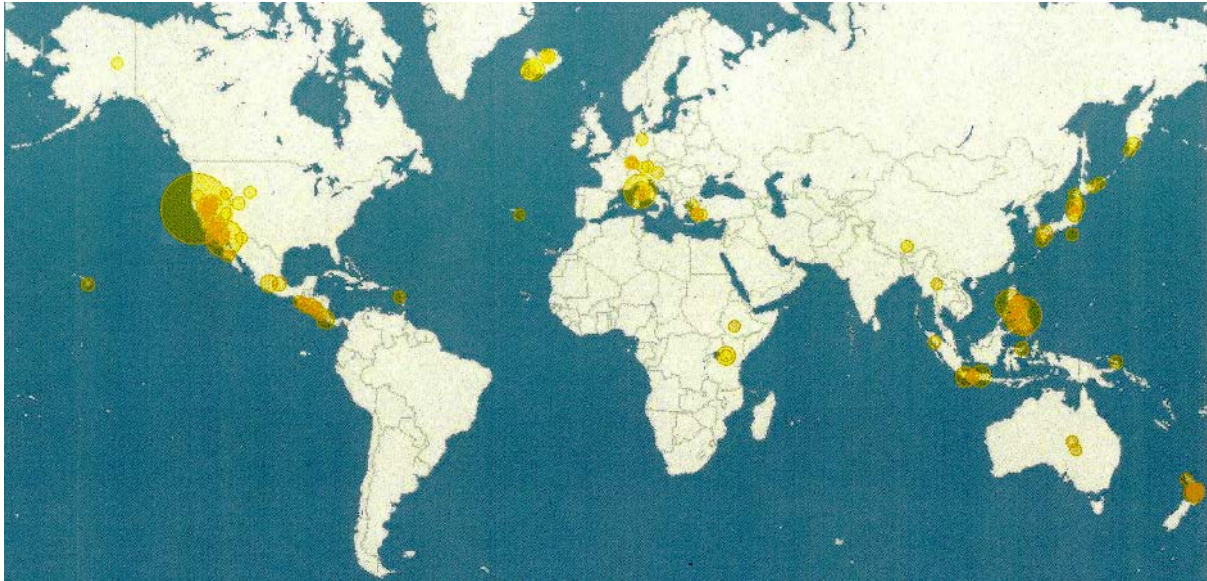

Figure 1. Power plants around the globe (yellow); the larger the circle, the higher the installed plant capacity.

Depending on the temperature and permeability of the geothermal resource, production wells can deliver to the surface, either dry steam, or two phase mixture of steam and liquid water, or only liquid water.

Only a handful of dry steam resources are encountered around the globe. The most important are the geothermal fields of Larderello, Italy, Geysers, California, and Kamojang, Indonesia. In such fields, the steam from the production wells is directly conveyed to a steam turbine in order to generate electricity. This is termed as a dry steam plant.

In most cases, production wells deliver a mixture of steam and liquid water, which is flashed in order to separate the steam and the liquid (flash plant); the steam is conveyed to a turbine to generate electricity and the separated liquid can be further utilized for power generation or for its heat (cogeneration plant) and then reinjected to its origin reservoir. A flash plant is economically feasible if the production wells deliver more than 150°C.

In cases where resource temperature is lower than 150°C, production wells deliver liquid water with the aid of a submersible or line shaft pump, which feeds a binary power plant. In such a plant, the hot water delivers its heat to a closed loop of secondary fluid, which vaporizes, drives a turbine and condenses in a closed cycle (organic Rankine or Kalina).

In general, exploitation of hydrothermal resources down to 3-4 km depth is a mature commercial technology done by:

- Binary plants for $T=100-180^{\circ}\text{C}$
- Flash plants for $T>180^{\circ}\text{C}$
- Dry steam at favourable locations

EGS from 3-6 km depth is a new technology, while supercritical plants ($T>350^{\circ}\text{C}$) from 5-10 km depth will be a future technology.

The geothermal power market in terms of historical evolution, present status and future projection of installed plants is summarized in Table 2 (world) and Table 3 (EU). Prediction of future installations was based on projects which are at present under development (2015) or announced (2020). The market is dominated by mostly dedicated geothermal field operators and lesser by diversified power utilities, with presence of oil and gas companies, mainly in Indonesia. The six major geothermal field owners and plant operators control >6,5 GWe or 60% of installed capacity.

At global level, market growth which was 3% during the past 20 years, is expected to exceed 10% in the next years, resulting in more than double installed geothermal capacity from 11,5 GW today to 24 GW by 2020. At EU level, market growth patterns are expected to increase from 2% today to 6% during the next years, due to wider geothermal development, as EU member states try to reach their 2020 targets for 20% less greenhouse gas emissions, 20% renewable energy share and 20% more energy efficiency, resulting in installed capacity to increase from less than 1 GW today to 1,5 GW in 2020.

Table 2. World geothermal power plant capacity.

MWe	historical evolution					present	forecast	
Country	1990	1995	2000	2005	2010	2012	2015	2020
USA	2.775	2.817	2.228	2.544	3.093	3.187	4.136	5.442
Philippines	891	1.227	1.909	1.931	1.904	1.972	2.112	3.447
Indonesia	145	310	590	797	1.197	1.335	2.325	3.453
Mexico	700	753	755	953	958	990	1.208	1.208
EU	552	641	805	822	896	941	1.113	1.499
New Zealand	283	286	437	435	628	750	1.350	1.599
Iceland	45	50	170	322	575	675	890	1.285
Japan	215	414	547	535	536	537	568	1.807
Kenya	45	45	45	127	167	205	402	560
El Salvador	95	105	161	151	204	204	287	290
Costa Rica	0	55	143	163	166	201	201	201
Nicaragua	35	70	70	77	88	124	209	240
Turkey	21	20	20	20	82	115	206	1.232
Russia	11	11	23	79	82	82	190	194
Papua NG	0	0	0	39	56	56	75	75
Guatemala	0	33	33	33	52	52	120	141
China	19	29	29	28	24	24	60	84
Ethiopia	0	0	9	7	7	7	45	70
Australia	0	0	0	0	1	1	43	70
Chilli	0	0	0	0	0	0	40	160
Honduras	0	0	0	0	0	0	35	35
Nevis	0	0	0	0	0	0	35	35
Argentina	1	1	0	0	0	0	30	300
Canada	0	0	0	0	0	0	20	493
Thailand	0	0	0	0	0	0	1	1
Bolivia	0	0	0	0	0	0	0	100
Iran	0	0	0	0	0	0	0	50
Peru	0	0	0	0	0	0	0	40
Armenia	0	0	0	0	0	0	0	25
Tanzania	0	0	0	0	0	0	0	20
Norway	0	0	0	0	0	0	0	5
Switzerland	0	0	0	0	0	0	0	3
	5.832	6.867	7.974	9.064	10.717	11.456	15.701	24.162

Table 3. Geothermal power plant capacity in EU member states.

MWe	historical evolution					present	forecast	
Country	1990	1995	2000	2005	2010	2012	2015	2020
Italy	545	632	785	790	843	883	923	1.019
Portugal	3	5	16	16	29	29	39	60
France	4	4	4	15	16	16	41	42
Germany	0	0	0	0	7	12	92	184
other	0	0	0	1	1	1	18	194
	552	641	805	822	896	941	1.113	1.499

The different types of installed geothermal power plants today are presented in Table 4, while the corresponding manufacturers and their market position in Table 5. Average plant sizes are 5 MWe binary, 30 MWe flash and 45 MWe dry steam, with maximum at around 100-130 MWe. Six major turbine manufacturers account for 95% of total installed capacity.

Table 4. Types of geothermal power plants installed today.

Geothermal plant type	installed MWe
Flash, condensing	6.904,3
Dry steam	2.862,0
Binary	1.303,0
Flash, back Pressure	146,6

Table 5. Geothermal power plant manufacturers with their corresponding installed capacity.

Manufacturer	Steam MWe	Binary MWe	total MWe
Mitsubishi	2.729		2.882
Toshiba	2.721	25	2.746
Fuji	2.315		2.423
Ormat		1.234	1.234
Ansaldo	1.556		1.556
General Electric	532		532
Alstom	155		155
Assoc. Elec. Ind.	90		90
Kaluga	72	10	82
British Thomson Houston	82		82
Mafi Trench		72	72
Qingdao Jieneng	62		62
UTC Turboden (MHI)		19	19
Kawasaki	15		15
Westinghouse	14		14
Elliot	12		12
Harbin	11		11
Enex		11	11
Turbine air system		8	8
Parsons	5		5
Makrotek	5		5
Siemens		4	4
misc.		3	3

The investment costs of geothermal power plants depend on the depth, temperature and chemistry of the resource, as well as the delivery flow rates of the wells. The dry steam, flash and binary plants in operation today exploit the most favourable resources usually from 2-3 km depth, going down to 4-5 km for EGS plants. Investment and levelized electricity generation costs in recent projects are shown in Table 6. Investment costs include exploration, field development and power plant.

In order to estimate the electricity generation costs presented in Table 6, typical operation costs of 0,011-0,020 €/kWh were assumed, an investment discount factor of 8% for 20 years,

as well load factors relevant to the installed country: 90% for USA, Portugal and Germany, 80% for Iceland and world average and 70% for Italy, Turkey and EU average.

The main aspects of global and EU geothermal power markets are summarized in Table 7.

Main market barriers hindering geothermal deployment are lengthy permitting procedures, lack of regulations, high risk in finding & identifying geothermal resources and associated finance availability, as well as know how and competent personnel to few companies only.

In USA, geothermal development is driven by federal and state incentives available to energy producers, manufacturers and utilities, which are summarized in Table 8. They include renewable portfolio standards, tax exemptions, investment subsidies and access to grid.

In EU, geothermal development is supported by feed in tariffs, with the tendency to be replaced by feed in premiums. Following the successful example of Germany, Japan, Indonesia and Turkey have recently introduced aggressive feed in tariff schemes, in order to stimulate large scale geothermal power development in their territory. A list of available feed in tariffs is presented in Table 9.

Table 6. Economic aspects of geothermal power generation.

recent projects	Investment, €/MWe			Energy production costs, €/kWh		
	Flash	Binary	EGS	Flash	Binary	EGS
USA	2.700.000	3.100.000	6.200.000	0,055	0,060	0,100
Indonesia, New Zealand, Philippines	2.300.000			0,044		
EU - Germany		4.500.000 6.500.000	11.600.000		0,095 0,104	0,213
Chile	3.600.000			0,072		
Turkey	2.750.000			0,066		

Table 7. Global and EU market size and growth

	2012			2012-2020	
	installed capacity MWe	annual sales		annual growth	
		electricity GWh	value billion €	capacity MWe	investments billion €
World	11.456	71.887	7,2	1.588	4,4
EU	941	5.982	0,9	70	0,5

Table 8. Incentives to geothermal electricity development in USA.

Jurisdiction	Statute	Incentive Title	Tax	Type	Taxpayer	yrs	Amount	Max	Expire
Federal	§45	Renewable Electricity Production	Income	Credit	Producer	10	\$0.022/Kwh	-	2013
	§48	Investment In Energy Property	Income	Credit	Owner	5	10%	-	2016
	§168(e)(3)	Certain Energy Property	Income	Deduction	Owner	5	200% DB	-	2016
Alabama	§40-18-190	Alternat. Energy Electricity Prod. Facilities	Income	Credit	Utility	20	5%	-	2015
	§40-9B-4	Alternative Energy Production Facilities	Property	Abatement	Utility	-	100%	-	2018
Florida	§196.175	Renewable Energy Source Devices	Property	Exemption	Owner	10	100%	-	-
	§220.193	Renewable Energy Production	Income	Credit	Producer	-	\$0.01/kWh	\$1 million	2016
Illinois	35 §10/5	Ren. En.eg & Conservation Job Creation	Income	Credit	Employer	10/15	Varies	-	-
Indiana	§6-1.1-22-26	Renewable Energy Property	Property	Exemption	Owner	-	100%	-	-
Kentucky	§154.27-010	Renewable Energy Facilities	Income	Credit	Producer	-	50%	-	-
	§154.27-010	Renewable Energy Facilities	Sales	Exemption	Purchaser	25	100%	-	-
Maryland	§10-720	Renewable Energy Production	Income	Credit	Producer	5	\$0.0085/kWh	\$2.5 million	2015
	§9-203	Solar, Geothermal & Conservation Devel.	Property	Credit	Owner	-	100%	-	-
	§7-242	Renewable Energy Systems	Property	Exemption	Owner	-	100%	-	-
Massachusetts	62§ 2a(2)(G)	Conservation / Alternative Energy Patents	Income	Deduction	Owner	5	100%	-	-
Michigan	§125.2681	Renewable Energy Renaissance Zones	Varies	Abatement	Owner	15	100%	-	-
Mississippi	§27-7-22.29	Alternative Energy Job Creation	Income	Credit	Employer	20	\$1,000/emp	100%	liab
	HB1701 2010	Clean Energy Manufacturing Facilities	Income	Exemption	Manufacturer	10	100%	-	-
	HB1701 2010	Clean Energy Manufacturing Facilities	Franchise	Exemption	Manufacturer	10	100%	-	-
	HB1701 2010	Clean Energy Manufacturing Facilities	Sales	Exemption	Manufacturer	10	100%	-	-
New Hampshire	72 §73	Renewable Generation Facilities	Property	Abatement	Owner	5	Varies	-	-
New Jersey	§54:10A	Alternative Energy Technology Company	Income	Credit	Investor	3	30%	\$500,000	-
	§54:4-3.113	Renewable Energy Systems	Property	Exemption	Owner	-	100%	-	-
North Carolina	§105-130.28	Renewable En. Property Manufacturing Fac.	Income	Credit	Manufacturer	5	25%	-	2013
Ohio	§3706	Air Quality Renewable/Energy Efficiency/Con	Property	Exemption	Owner	-	100%	-	-
Pennsylvania	73 §1649.701	Alternative Energy Production	Income	Credit	Producer	-	15%	\$1 million	2016
Rhode island	§44-18-30(57)	Renewable Energy Systems & Equipment	Sales	Exemption	Purchaser	-	100%	-	-
	§44-3-21	Renewable-Energy Systems	Property	Exemption	Owner	-	100%	-	-
South Carolina	§12-6-3588	Renewable En. Manufacturing Plant/Equip	Income	Credit	Owner	15	10%	\$5 million	2015
Tennessee	§67-6-232	Manufacturers Of Clean Energy Tech.	Sales	Credit	Manufacturer	8	99.50%	-	-
	§67-4-2109(n)	Green Energy Supply Chain Manufacturers	Income	Credit	Manufacturer	-	100%	-	2028
Vermont	HB446 2009	Clean Energy Assessment Districts	Property	Financing	Owner	-	Varies	-	-
	32 §9741(46)	Renewable-Energy Systems	Sales	Exemption	Purchaser	-	100%	-	-
Virginia	§15.2-958.3	Clean Energy Assessment Districts	Property	Financing	Owner	-	Varies	-	-
	§58.1-3221.4	Renewable Energy Manufacturing	Property	Assessment	Manufacturer	-	Varies	-	-
	§58.1-439.12:03	Green Job Creation	Income	Credit	Employer	5	\$500/job	\$175,000	2014
Wisconsin	§66.0627 (8)	Renewable En. & Energy-Efficiency Project	Property	Financing	Owner	-	Varies	-	-

Table 9. Feed in tariffs (in black) and premiums (in red).

country	€/kWh	country	€/kWh	country	€/kWh
Japan		Italy		Estonia	
<15MW	0,4077	- feed-in premium	0,1300	- feed-in premium	0,0537
>15MW	0,2692		0,0800		
Switzerland		Croatia	0,1590	Romania max-min	0,1100
<5 MW	0,3330			- feed-in tariff equiv.	0,0540
>20MW	0,1890			2 green cert. per MWh	
Germany		Slovenia		Hungary	
- EGS	0,3000	- feed-in tariff	0,1525	- max	0,1070
- other	0,2500	- feed-in premium	0,1036	- min	0,0390
France continental		UK		Turkey	
- max	0,2800	- feed-in tariff equiv.	0,1422	- max	0,1020
- min	0,2000	2 ROCs per MWh		- min	0,0810
France overseas		Indonesia		Belgium	
- max	0,1600	- max	0,1308	green certificates (min)	0,0900
- min	0,1300	- min	0,0833		
Slovakia	0,1905	Greece	0,1220	Portugal – Azores	0,0840
				Austria	0,0743
Czech Republic		Netherlands		Spain	
- feed-in tariff	0,1810	- feed-in premium	0,0680	- feed-in tariff	0,076467
- feed-in premium	0,1420			- feed-in premium	0,042667

Table 10. Developers of new geothermal power projects.

Company	Location	Core Business	operating, MWe	new projects, MWe
Gradient resources	USA	Geothermal	0	1025
Pertamina	Indonesia	Oil & gas	642	875
Oski Energy	USA	Geothermal	0,8	655
Ram Power	USA, global	Geothermal	40	610
Enel	Italy, global	Power utility	955	505
Contact Energy	New Zealand	Power utility	336	490
Landvirksjun	Iceland	Geothermal	63	480
CallEnergy	USA	Power utility	329	470
Calpine	USA	Power producer	1309	420
Idatherm	USA	Geothermal	0	400
Ormat	USA, global	Geothermal	777	350
US Geothermal	USA	Geothermal	54	350
Itochu	Japan, Indonesia	Trade & investments	0	330
EDC	Philippines	Geothermal	756	305
KenGen	Kenya	Power producer	150	280
Altera	USA, global	Power producer	198	280
Zorlu	Turkey	Power producer	15	185
Terra-Gen	USA	Power utility	392	180
			total:	8190

In developing countries support sources to geothermal projects are carbon credits and loans from World Bank (\$336 million in 2012, \$1710 million overall), Japan International Co-operation Agency, French Development Agency, European Investment Bank (\$256 million), German development bank KfW, African Development Bank (\$129 million), Asian development bank (\$557 million), Interamerican development bank (\$416 million) as well as national development banks .

Global geothermal market development is done by ambitious new-coming companies, the most important of which correspond to ~65% of total power plant capacity under development worldwide and are presented in Table 10.

References

BP: statistical review of world energy 2012.

Emerging energy research: global geothermal market and strategies 2009-2020.

European geothermal energy council (EGEC): deep geothermal market report 2012.

Geothermal energy association (GEA): geothermal international market overview report (2012); annual US geothermal power production and development report (2012).

International energy agency (IEA): technology roadmap, geothermal heat and power (2011).

International geothermal association (IGA): geothermal database.

Jerome L. Garciano, Klein Hornig LLP (2013): Energy Efficiency and Renewable Energy Tax Incentives, Federal and State Energy Tax Programs.

New Zealand geothermal association (NZGA): web site.

Session VI - Legal, environmental and financial aspects

L. Angelino, R. Barontini, F. Batini, M. Borzoni, P. Dumas, M. Frey, F. Jaudin, R. Kutschick, I. Nardini, T. Reif, F. Rizzi, B. Sanner, L. Tryggvadóttir and G. Wolter

Sustainable development of a geothermal project

The sustainable use of geothermal energy for the generation of electricity and/or heat depends to a decisive extent on the resource characteristic, its availability for the total life of the project, which in turn requires sufficient volumes of fluid at sufficient temperatures.

In most cases, the high capital costs, inflated by the drilling costs as well as by the cost of the infrastructure to reach the remote location of the projects are the main deterrents for the investors.

Finally, the environmental, social and regulatory constraints might represent a substantial barriers to execute the projects.

The main goals of this lecture is to provide the technological and economic background for the evaluation and development of geothermal projects. Emphasis will be placed on regulatory, environmental and economic issues affecting the risk assessment and the decision making process:

- How to evaluate the performance of different geothermal projects according to the triple bottom line of sustainability (technology, environment and economics)
- How to assess, mitigate and manage the risks associated to development and operation of the geothermal project
- How to involve local stakeholder in project development in order to obtain the social acceptance

The main topics to be covered during the course are:

- An overview of the main phases for a geothermal project;
- Drivers and hurdles for geothermal development, including technological challenges, environmental compatibility, economic sustainability.
- Criteria for the evaluation and ranking of the green field projects. Resource availability and sustainability along the lifetime of the projects as well as the potential environmental impacts are key factors to be taken in account for risk assessment, mitigation and management.
- Development strategy: a case study will be discussed for risk analysis and decision making process application.

Risk insurance for geothermal projects

Any industrial project is exposed to risks, even if these risks do not ultimately materialize.

Nevertheless, unlike any common project, a geothermal one undergoes an additional particular risk that lies in the geological characteristic of the geothermal resource. This risk, known as the geological risk, is an inherent part of any geothermal project.

The geological risk covers:

- *The short-term risk of not finding a sufficient geothermal resource (temperature and flow rate) during the drilling phase for an economically sustainable project to take place;*
- *The long-term risk of the geothermal resource depleting over time rendering the whole project economically unprofitable once operation of the geothermal plant has taken place;*

Regardless of the thoroughness of the exploration phase that takes place upstream the drilling phase, the geological risk can only be fully purged when drilling confirms the expected temperature and flow rate. Likewise, in spite of the geothermal plant being operated, there is no guarantee that the original conditions remain over time and that the original temperature and flow rate will not decline.

When considering the geological risk, it is therefore the whole financing of the geothermal electricity project which is at stake. Geothermal projects require high upfront investments that will never be unleashed unless the geological risk is adequately handled. Yet, this can only be achieved by obtaining an insurance policy for the geological risk.

There are different insurance designs existing in Europe to cover the geological risk. Apart from Germany where the private insurance sector engaged in providing market-based insurance policies for geothermal projects, insurance is usually made available from national insurance funds that have been set up on the initiative of governments willing to support geothermal development.

In this respect, national funds may either offer a post-damage guarantee for the geological risk (e.g. France, The Netherlands, Switzerland) or a guaranteed loan, which is forgiven in case the risk materializes (e.g. Germany, Iceland). Both insurance concepts offer pros and cons. However, they undoubtedly contribute to the strengthening of confidence into the geothermal sector.

In this context, insurance is of such significant importance for geothermal electricity development that it is the interest of all European policy makers and investors to give some consideration to the establishment of a European insurance fund to cover the geological risk at European stage.

This contribution to the training course deals with the notion of geological risk and provides an insight into the different existing insurance concepts that cover such a risk in Europe. Last but not least, an overview of a proposed European Geothermal Risk Insurance Fund (EGRIF) covering the geological risk in Europe is also discussed.

References

- GEOFAR (Geothermal Finance and Awareness in European Regions) report: Financial instruments as support for the exploitation of geothermal energy, 2009.*
- GEOELEC (Develop Geothermal Electricity in Europe to have a renewable energy mix) Report on risk insurance, 2013.*

Regulatory barriers

Barriers against geothermal power plants can result from:

- *Uncertainty with resource ownership, difficult procedures for obtaining exploitation rights – in a number of countries solved satisfactory*
- *Environmental regulations need to take a wise approach, protecting the environment but not killing projects, wherever possible*
- *Secured grid access is a must for geothermal power – in some countries solved within legislation e.g. for feed-in-tariffs, for all stipulated in RES Directive*
- *Public acceptance problems must be taken seriously and solved, even if not required legally*
-

Main areas of legal problems and regulatory barriers

Definition

A basic problem EU-wide was solved by the Directive on Renewable energy sources (2009/28/EC), with a binding definition of Geothermal Energy in the Article 2:

(c) ‘geothermal energy’ means energy stored in the form of heat beneath the surface of solid earth;

Ownership of the resource / license for using the resource

A clear title for exploitation rights over a sufficient period is crucial

For a renewable energy, „exploitation“ might not be the best wording; the energy extraction should be seen more as a use of the resource, a temporary exploitation and recovery, or similar.

Protection of the resource against other uses/users

No licenses for other uses/users that would jeopardize the resource

Certain distance (or other protection) must be kept for other uses

Environmental regulations

It includes Groundwater protection incl. pressure issues, soil protection but also protocol on micro-seismicity, and surface issues.

Work safety, construction, traffic

Any legislation applicable for similar activities in mining, drilling, construction, etc.

Grid access

For geothermal power, grid access is a top issue

It is important to have secured right of connection, or a negotiation with grid operator (who actually might be a competitor). All regulations for electricity grids apply to geothermal power plants!

Regulatory barriers can also result in cost barriers

These financial burdens include:

- Cost for legal fees, license fees
- Cost for royalties => in particular problematic if fixed and not related to production!
- Cost for environmental studies, public hearings, etc.pp.

Dividing legal and regulatory barriers into impact groups:

- Uncertainty, lack of protection: in case no clear title for exploitation can be obtained, and/or no protection against other uses/users, the basis for investment is absent
- Timing: Procedures for obtaining the basic rights to the resource, Procedures for practical exploitation (environment, neighbours, etc.), Procedures for grid connection
- Cost, as stated on below
- No grid connection – no sales of power

1) Resource ownership and protection

Who actually owns the geothermal resource? Options are:

- The state / the crown
 - could be stipulated e.g. in mining law or in mineral resources law,
 - it is a good option if licensing is regulated properly;
 - but it's more difficult if included in water legislation
- The owner of the ground on surface
 - It creates difficult situation, as for a larger project multiple owners will be concerned;
 - for deep geothermal project this is very time consuming
- Not regulated
 - It is considered as a worst case, because deep geothermal projects are almost impossible

2) Resource licensing

In case the ownership is with the state, the following items are crucial for geothermal development:

- Who can apply for a license (non-discriminatory process)

- One- or two-step-process (exploration, exploitation)
- Time period for which a license can be obtained, possible prolongations
- Royalties (based upon what parameter? Fixed or as a percentage of production?)
- Time for obtaining a license

3) Environmental regulations

The state has a duty to provide regulations protecting the environment or other human interests from possible negative consequences of geothermal power production.

The following rules should be adhered to:

- A viable equilibrium has to be found between regulations that might have not the necessary protective effect, and those that might kill geothermal development
- Full Environmental Impact Assessment (EIA) procedures is required only for large projects with considerable risk potential
- Keep environmental regulations focussed on the protection of ground, groundwater, surface from possible harm caused by the geothermal plant, and do not address unrelated issues!

Regarding the protection of waters, Article 11 of Directive 2000/60/EC (Water Framework Directive) gives member states the option to authorise the reinjection into the same aquifer of water used for geothermal purposes. It is therefore within the competence of the national governments to decide as to whether reinjection of the geothermal fluids is required.

Negative examples:

- A confusion is made of fracking for shale gas with EGS stimulation, and all stimulation actions are banned (e.g. German state NRW)
- Drilling and safety regulations for hydrocarbon exploitation are imposed on geothermal drilling

The list of barriers from environmental regulations can be rather long. There will, of course, be cases where environmental issues make a project impossible. However, this should be limited to as few cases as possible, and be known as early in the project as possible!

4) Grid access

Within Directive 2009/28/EC grid access is treated in Art. 16:

- Art. 16, 2

(a) Member States shall ensure that transmission system operators and distribution system operators in their territory guarantee the transmission and distribution of electricity produced from renewable energy sources;

(b) Member States shall also provide for either priority access or guaranteed access to the grid-system of electricity produced from renewable energy sources;

- Art. 16, 3

Member States shall require transmission system operators and distribution system operators to set up and make public their standard rules ...

Summary

Barriers against geothermal power plants can result from:

- Uncertainty with resource ownership, difficult procedures for obtaining exploitation rights – in a number of countries solved satisfactory
- Environmental regulations need to take a wise approach, protecting the environment but not killing projects, wherever possible
- Secured grid access is a must for geothermal power – in some countries solved within legislation e.g. for feed-in-tariffs, for all stipulated in RES Directive
- Public acceptance problems must be taken seriously and solved, even if not required legally

Financing costs of geothermal power projects

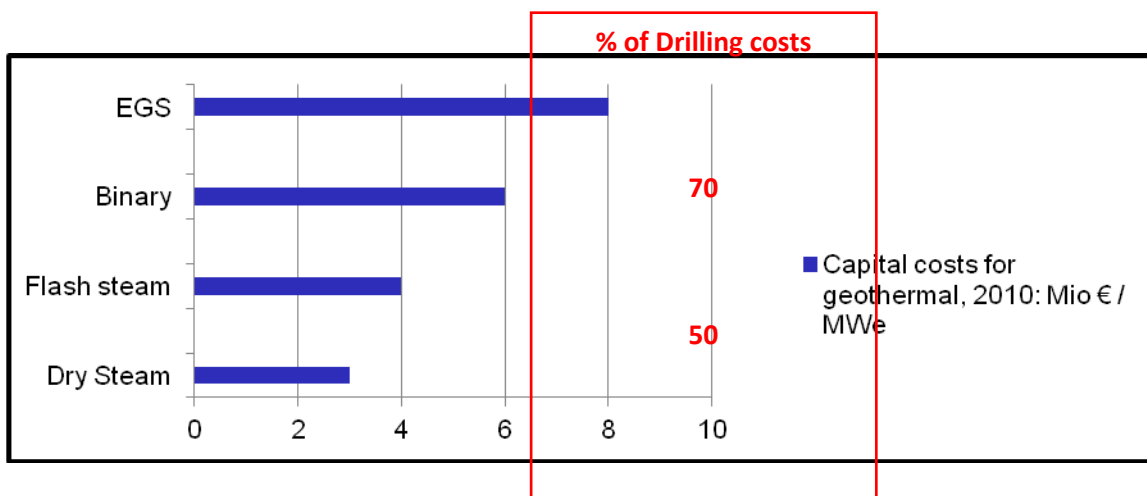

Figure 1. Average capital Costs of geothermal technologies, and percentage of the drilling costs for each technology. (Copyrights: EGEC Geothermal Market report 2012).

Table 1. Levelised costs of geothermal electricity (EGEC Copyrights).

LCoE of Geothermal Electricity	Costs 2012		Costs 2030
	Range(€/kWh)	Average (€/kWh)	Average (€/kWh)
Electricity Conventional – high T°	0,05 to 0,09	0,07	0,03
Low temperature	0,10 to 0,20	0,15	0,07
Enhanced Geothermal Systems	0,20 to 0,30	0,25	0,07

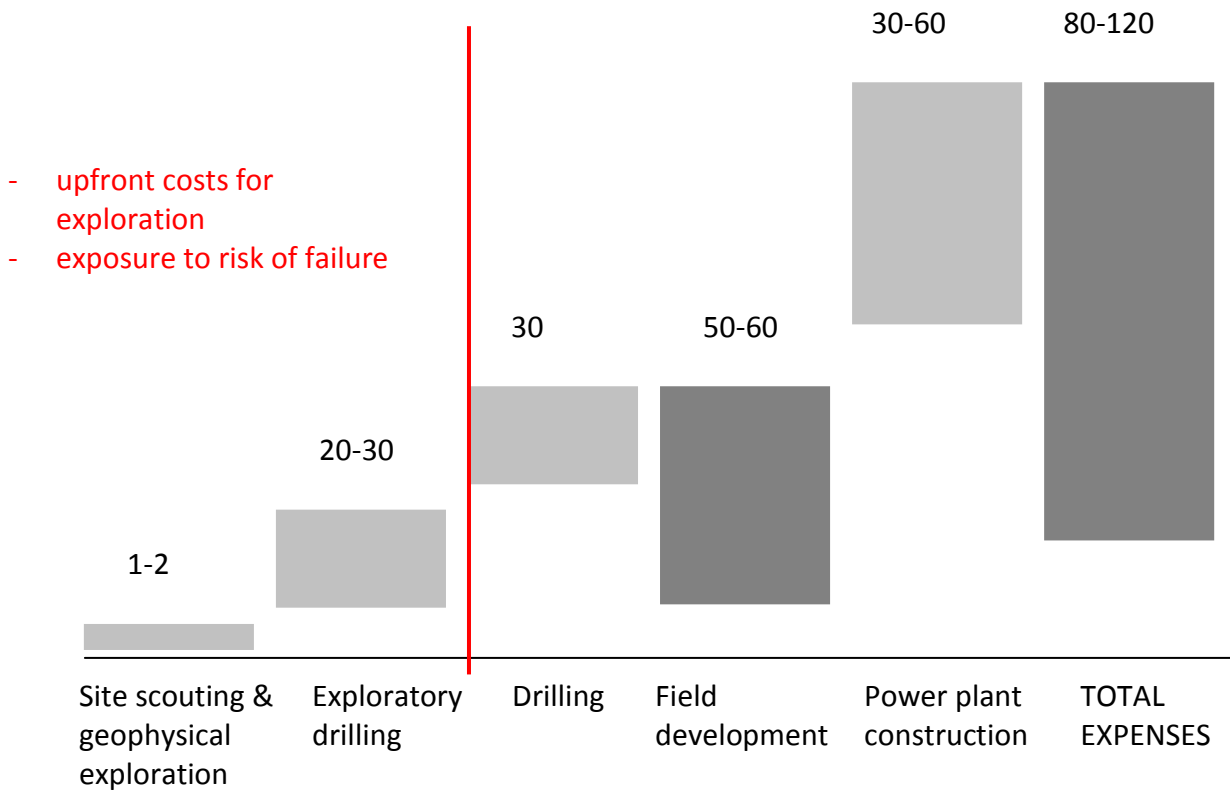

Figure 2. Geothermal power plant capital cost analysis in € million, based on a 20 MWe conventional high temperature plant (EGEC Copyrights).

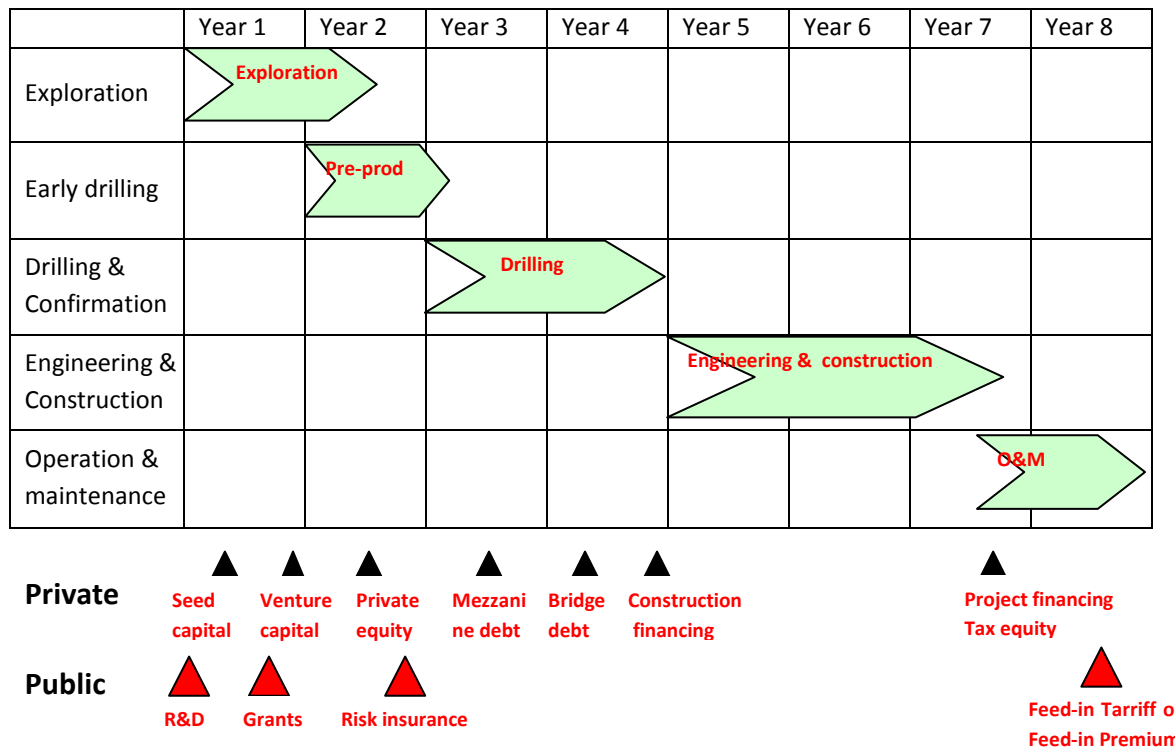

Figure 3. Funding mechanisms for geothermal projects (EGEC Copyrights).

Investment analysis

Beside being technologically and environmentally sound, geothermal projects have to be carefully assessed under an economic and financial perspective before being considered for the development phase.

In performing such assessment, unfortunately, different approaches could lead to different results, and these results could have not the same meaning depending on the investor. As a consequence, the analyst has to be able to understand which approach suits better in view of relevant performances for the target stakeholder of the project.

Grounding on that, the session entitled “Investment analysis” will provide the knowledge base to start orienting in this field.

The lecture will be divided in two main sessions. The first, will introduce the basic concepts of economic and financial analysis. Starting from theoretical aspects, the peculiarities of the geothermal sector will be introduced in order to focus on the key aspects in this field. The second, will introduce the presence of a plurality of different perspectives and values that emerge when social, environmental and economic aspects are brought together in a single evaluation framework. The process that lead to the selection of compromise solutions will be explained in order to understand why multi-interdisciplinary, participation and transparency are necessary conditions to achieve a satisfactory result.

In detail, the session will cover the following issues:

- Introduction on the logics of the financial analysis;
- The fundamentals of cash flow estimation;
- Introduction to cost of capital;

- The choice between alternative projects;
- Discussion on the critical aspects of making decisions under capital rationing;
- How reductionist approaches differ from non-reductionists one;
- Introduction to the social multi-criteria evaluation.
- Real-case and ad-hoc examples, as well as short exercises, will help students in linking their theoretical knowledge with the practical world.

Relevant publications

- Dumas, P. Angelino, L. (2013). *EGEC Policy Paper "Financing Geothermal Energy"*. Brussels, Belgium.
- Borzoni, M., Frey, M., Rizzi, F. (2013) *Assessing the sustainability of energy and environmental policies in the era of the green economy*. In Agustoni, A. and Maretti, M (Eds) *Energy issues and social sciences: theory and applications*. Mc-Graw-Hill. Pp. 45-60.
- Borzoni, M. (2011). *Multi-scale integrated assessment of soybean biodiesel in Brazil*. *Ecological Economics*, 70 (11). pp 2028-2038
- Borzoni, M. Rizzi, F. Frey (2012). *Social-multi criteria evaluation of alternative geothermal power scenarios: the case of Mt. Amiata in Italy*. Paper presented at the bi-annual conference for *Ecological Economics*, Rio De Janeiro. Available from the annals of the conference.
- Borzoni, M. Contini, C. Cordoba, D. M. Omodei Zorini, L. (2008). *Managing the uncertainties of long-term strategies: a methodological proposal*. In Dedieu, B. and Zasser-Bedoya, S. (Eds). *Book of abstract of the 8th European IFSA Symposium*. GN Impressions, Bouloc, p.89
- Rizzi, F. Borzoni, M. (2010). *An evolutionary triple helix to strengthen energy regulation: implications for management*. *Annals of the XXI World Energy Congress*. Montréal, Canada.
- Gasparatos, A. Borzoni, M. Abramovay, R. (2012). *The Brazilian bioethanol and biodiesel programmes: an integrated analysis of their environmental, social and economic impacts*. In Gasparatos, A. & Stromberg, P. (Eds) *Socioeconomic and Environmental Impacts of Biofuels: Evidence from Developing Nations*. Cambridge University Press. Pp 111-143
- GEOELEC (*Develop Geothermal Electricity in Europe to have a renewable energy mix*) *Report on geothermal regulations, 2013*.

Environmental issues

Geothermal facilities for exploiting high and medium enthalpy hydrothermal resources and Enhanced Geothermal Systems (EGS) can be connected to different potential environmental impacts.

Each phase during the development of a geothermal project (including the power plant construction) may be related to various impact factors. Those main phases are:

- Access roads and pipe laying
- Well repair, well stimulation, well drilling and testing phase
- Plant construction and equipment installation
- Power plant commissioning and operation
- Decommissioning of facilities

Different impacts can be generated in different phases of the development but the following main categories were identified:

- Surface disturbances, such as those caused during the plant construction possibly affecting flora, fauna, surface water (access roads, pipe and power lines, plant and associated land use).
- Physical effects, like the effect of fluid withdrawal on natural manifestations, land subsidence, induced seismicity, visual effects (buildings, cooling towers, surface pipelines, power transmission lines etc.)
- Noise, such as equipment noise during drilling, construction and operation.
- Thermal pollution, such as due to hot liquid and steam release on the surface.
- Chemical pollution, like due to disposal of liquid and solid waste, gaseous emission to the atmosphere etc.
- Protection, such as ecological protection (fauna and flora).

Most of the impact identified can be minimised by mitigation measures and monitoring along with proper environmental management procedures.

Day 4 - 8 October 2013

Presenters

A. Lazzarotto, L. Serniotti and R. Parri

Curricula vitae

	<p>Alessandro Lazzarotto Head of Drilling Unit, Enel Green Power - E&C/Construction, Italy alessandro.lazzarotto@enel.com</p>
---	--

Alessandro Lazzarotto got a MSc Degree in Mechanical Engineering, in 1991, at Pisa University. During his studies, in 1989, he won two scholarships from Solvay Italy and Dow Italy. In 1992 he had one year of experience in Nuovo Pignone, Florence, in the research and development of new axial and centrifugal compressors, in projects of an international character. In 1992 he started his career in Enel and gained over 10 years of professional experience in design, project management and construction of geothermal power plants. In 2006 he was in charge of drilling unit of Enel Green Power.

As Drilling Unit manager, he managed many geothermal drilling projects in Italy and abroad of which the main ones are:

- 2006-2013: about 50 deep exploration and exploitation wells in Italian geothermal fields;
- 2012-2013: 7 exploration slim hole wells drilled in Turkey – Alasheir, Simav, Gediz;
- 2008-2010: 5 exploration wells drilled in Chile – El Tatio, Apaceta, at 4500m above ground level;
- 2007-2010: total development of wells for 3 new geothermal power plants in U.S.A;
- 2003-2006: total development of wells for a new 40MW geothermal power plant in Salvador.

He gained considerable experience in management of complex mining structures, with independent budgets and international projects.



Luca Serniotti

Drilling Development Team leader,
Enel Green Power
E&C/Construction/Drilling, Italy
luca.serniotti@enel.com

Luca Serniotti got his MSc Degree in Mechanical Engineering in 2007 at Florence University. During his studies, he had two internship contracts. The first one in 2004 at Consiag Reti, local utility company and gas supplier, making a technical, environmental and economical study on gas absorption heat pumps. The second one in 2007 collaborating with three firms of Prato textile district, working on the concurrent design of a packaging machine. In 2007 he started his career in Enel and held over 5 years of professional experience in the geothermal, dealing with well design and project management. Since 2011 he is in charge of the Drilling Development Team within the Drilling Unit of Enel Green Power, managing geothermal drilling activities of Enel in Italy and abroad.

Session VII - Drilling

R. Bertani, A. Lazzarotto and L. Serniotti

Abstract

Geothermal industrial applications began in the early 1900s in the area of Larderello. Since then, the Italian geothermal system was characterized by a constant evolution and currently consists of about 500 wells in operation and 33 geothermal power plants. For the maintenance and development of such a system, EGP has a drilling unit able to manage all phases of the drilling process. The ability to manage the process in an integrated manner and the experience gained over the years have allowed EGP to develop new projects, even complex, in the international scenario. Our challenge is to use the experience of the past as a support and stimulus to the ideas of the future.

Experience has taught us that the development of any geothermal project must be characterized by:

- *safety;*
- *environmental compliance;*
- *focus on costs.*

The course provides a survey of technical solutions and related costs for drilling and completion of geothermal production and reinjection wells, for different types of geothermal wells and their appropriate casing schemes.

A special focus will be on the directional drilling: in the drilling world, the use of one drilling pad to drill many wells in cluster, reaching several mining targets in the surrounding area, allows a greater respect for the environment and a reduction in the associated costs; therefore directional drilling becomes an essential tool to ensure sustainability of the activity. The challenges ahead in terms of directional are the application of multilateral technology and the development of monitoring systems for the risk of collision with the existing wells. A selection of Case Studies will be presented

Keywords: geothermal, directional drilling, anticollision system

PARTNERS

